



MINISTERO DELLE INFRASTRUTTURE E DEI TRASPORTI
DIPARTIMENTO PER I TRASPORTI, LA NAVIGAZIONE,
GLI AFFARI GENERALI E IL PERSONALE
DIREZIONE GENERALE TERRITORIALE DEL NORD-OVEST
CPA DI MILANO

Milano, **25 GEN. 2018**

Spett.le

ANDREA DE SANTIS

Mandatario della Ditta:

JIANGMEN PENGCHENG HELMETS LTD

p.c. ANCMA - Milano

Marca operativa n° **10MI/167609**

all. Vari

OGGETTO: Omologazione casco LS2 tipo **FF324-2**.

In esito a quanto richiesto con la domanda del 04.09.2017, marca operativa n° **10MI/167609** si comunica che, a seguito degli accertamenti effettuati si è provveduto a rilasciare la omologazione del dispositivo indicato in oggetto ai sensi del Regolamento ECE/ONU n° 22/05.

Si trasmette il certificato di omologazione n° **E3 052882/P-J** del 11.01.2018 e la documentazione tecnica del dispositivo, già allegata alla citata domanda.

In merito si fa presente che il numero di omologazione deve essere riportato su ogni etichetta del casco indicata in oggetto.

Responsabile del procedimento: Funzionario Tecnico Angela MARFUGGI.

Il Direttore

Ing. Henry Del Greco





Imposta di bollo
assolta mediante
versamento in c/c
postale ai sensi
dell'art. 7 della
legge 18/10/1978
n. 625.

**MINISTERO DELLE INFRASTRUTTURE E DEI TRASPORTI
DIPARTIMENTO PER I TRASPORTI, LA NAVIGAZIONE,
GLI AFFARI GENERALI E IL PERSONALE
DIREZIONE GENERALE TERRITORIALE DEL NORD-OVEST
CPA MILANO**



Communication concerning the approval (or refusal or withdrawal of approval or production definitely discontinued) of a type of head protection for drivers and passengers of motorcycles and mopeds, pursuant to Regulation No 22/05

concernant (*): APPROVAL GRANTED
APPROVAL EXTENDED
APPROVAL REFUSED
APPROVAL WITHDRAWN
PRODUCTION DEFINITELY DISCONTINUED

Of a type of protective helmet without/with/with 2/ one/more-2/ visor type (s) pursuant to Regulation N° 22

Approval number: E3 052882/P-J.

Extension No: //

1. Trade mark: LS2 ; MHR
2. Type: FF324-2
3. Sizes: XXS 51/52-XS 53/54-S 55/56 M 57/58-L 59/60 XL 61/62-XXL 63/64-XXXL 65/66
4. Manufacturer's name: JIANGMEN PENGCHENG HELMETS LTD
5. Address: No. 01-7 Dongsheng Road, Gonghe Town, Heshan City, Giangdong Prov. 52928 P.R. CHINA
6. If applicable, name of manufacturer's representative: Andrea De Santis
7. Address: Via Labriola n° 25 - 58100 GROSSETO
8. Brief description of helmet: Calotta in ABS e cinturino. Imbottitura di protezione in polistirolo espanso
(Calotte in ABS and chin strap. Polystyrene foam protective padding)
9. Helmet without lower face cover (J) / with protective lower face cover (P) / with no protective lower face cover (NP)
10. Type of visor or visors: mod. FF-MHR-77 (E1 05300507)
11. Brief description of visor or visors: Policarbonato con trattamento
(polycarbonate with treatment)
12. Submitted for approval on: 04.09.2017
13. Technical service responsible for conducting approval tests: C.P.A. di MILANO
14. Date of report issued by that service: 11.01.2018
15. Number of report issued by that service: 00019/CPA-MI/2018
16. Comments: Denom. Comm. LS2, MHR, TAKAI, SPYDER, HELD, A-PRO, SPARX, FULMER, KENNY, NOX, VENOM, SPEED AND STRENGTH, JOE ROCKET, SPEEDWAY, EXKLUSIV, DEXTER, DROXX, ROCC, NEXO, AXO, NITRO, FFM, TAKACHI, STELS, S-LINE, BAYARD, G-MAC, FLINT, TRIK MOTO, SPIRIT, X-VINCE, SHAFT-PRO, KONTROL, SMOOK, IXS, FIRST RACING, RXA, VOSS, ZOXX, CX RACING, BOX, SWIFT, SYKO, CMS, MAC, OXFORD, BiLT, SEDICI, SKULLY, XPLORER, DIEFFE, STREET&STEEL, TUZO, TEXX, LIFESTYLE, KOJI, HARLEY DAVIDSON, GUN, SHELL; FF324-D, METRO EVO; FF324-C; FF324-A; METRO V3; METRO. Il casco è stato testato anche in configurazione Jet.
(The helmet was also tested in Jet configuration)
17. Place: MILANO
18. Date: 11.01.2018
19. Signature: Il Direttore Ing. Henry Del Greco
20. The following documents, bearing the approval number shown above are available on request:
Trial-report and drawing..

(#) Delete as appropriate



MINISTERO DELLE INFRASTRUTTURE E DEI TRASPORTI

DIPARTIMENTO PER I TRASPORTI, LA NAVIGAZIONE,
GLI AFFARI GENERALI E IL PERSONALE
DIREZIONE GENERALE TERRITORIALE DEL NORD - OVEST
CENTRO PROVE AUTOVEICOLI
DI MILANO

Verbale n° 00019/CPA-MI/18 del 11.01.2018

VERBALE DELLE VERIFICHE E PROVE DI OMOLOGAZIONE DEL CASCO PER CONDUCENTI
E PASSEGGERI DI MOTOCICLI E CICLOMOTORI AI SENSI DEL REGOLAMENTO ECE/ONU
N. 22 emend.05

Dispositivo: casco tipo: **FF324-2**

- Costruttore: **JIANGMEN PENGCHENG HELMETS LTD
NO.01-7, DONGSHENG ROAD,
GONGHE TOWN, HESHAN CITY,
GIANGDONG PROV. 52928 P.R. CHINA**

- Mandatario: **Andrea De Santis
Via Labriola 25 – GROSSETO**

- Marchio di fabbrica: **LS2; MHR**

Domanda omologazione marca operativa: **10MI/167609 del 05.09.2017**

Data ultimazione della prova: **19.12.2017**

DESCRIZIONE DEL DISPOSITIVO

Marchio di fabbrica o di commercio: **LS2, MHR, TAKAI, SPYDER, HELD, A-PRO, SPARX,
FULMER, KENNY, NOX, VENOM, SPEED AND STRENGTH, JOE ROCKET, SPEEDWAY, EXKLUSIV,
DEXTER, DROXX, ROCC, NEXO, AXO, NITRO, FFM, TAKACHI, STELS, S-LINE, BAYARD, G-MAC, FLINT,
TRIK MOTO, SPIRIT, X-VINCE, SHAFT-PRO, KONTROL, SMOOK, IXS, FIRST RACING, RXA, VOSS, ZOZ,
CX RACING, BOX, SWIFT, SYKO, CMS, MAC, OXFORD, BiLT, SEDICI, SKULLY, XPLOERER, DIEFFE,
STREET&STEEL, TUZO, TEXX, LIFESTYLE, KOJI, HARLEY DAVIDSON, GUN, SHELL**

Tipo: **FF324-2**

Denominazioni Commerciali: **FF324-D, METRO EVO; FF324-C; FF324-A; METRO V3;
METRO**

Assortimento taglie : **XXXL 65/66-XXL 63/64-XL 61/62 L 59/60-M 57/58
S 55/56-XS 53/54-XXS 51/52**

Massa complessiva: **XXXL-XL:1750 ± 50g; L-M :1650 ± 50g; S-XXS:1600 ± 50g**

Presenza marcature(*): **1-2-3-4 su calotta esterna
5 non ricorre
6 su cartoncino attaccato al cinturino**

(*) 1) Costruttore 2) Modello 3) Taglia 4) Massa 5) Non idoneità della protezione mascellare 6) Prescr. da §14.1 a §14.4

CARATTERISTICHE PRINCIPALI DEL CASCO

(Vedi scheda Informativa n° FF324-2/17/00 e disegni del costruttore)

- Calotta esterna: ABS in 3 calotte:
XXXL 65/66-XXL 63/64-XL 61/62
L 59/60-M 57/58
S 55/56-XS 53/54-XXS 51/52
- Imbottitura di protezione: EPS densità: (XXS-XS-S) dens. 50+40+85; (M) dens. 55+65+85;
(L) dens. 65+80+85; (XL-XXL-XXXL) dens. 60+80+85
- Imbottitura di conforto: Poliuretano espanso accoppiato a tessuto sintetico, spessore variabile in funzione della taglia
- Sistema di tenuta:
 - Fibbia: a) Anelli doppia D in acciaio
b) Micrometrica mod. 10 in acciaio e policarbonato
 - Rivetti: Acciaio
 - Staffe: Acciaio
 - Cinturino: Poliestere larghezza 22 mm (Micrometriche); 25mm (Anelli).
- Mentoniera: EPS + Poliuretano espanso Doppio codice P/J
- Liv. Protezione Mentoniera P NP J
- Bande Rifrangenti: Si No Tipo: 3M 13050 Scotchlite Reflective Sheeting
Le bande verranno applicate sui caschi destinati a quei paesi che ne fanno esplicita richiesta.
- Presenza integrata sul casco di visiere da sottoporre a prove: Si No
- Visiere: FF-MHR-77 (E1 05300507)
- Osservazioni: //
- Accessori: Visierino parasole

RIEPILOGO DEI RISULTATI DI PROVA

Le verifiche e prove sono state effettuate sulla base delle prescrizioni previste dalle condizioni generali del Regolamento ECE/ONU 22 emendamento 05 e di quelle indicate per ciascuna tipologia di prova.

§ Rif.	Verifiche e prove	Conforme	Non Conforme	Non Ricorre	Note	All.
CASCO						
6.7	Prescrizioni generali del casco	√				1
7.3	Assorbimento d'urto	√				2
7.4.2.1.3.1	Sporgenze ed attrito della superficie calotta	√				3
7.4.2.1.3.2						
7.5	Rigidità	√				3
7.6;	Dinamica del sistema di tenuta	√				3
7.7	Scalzamento	√				3
7.9	Microscorrimento del cinturino	√				3
7.10	Resistenza alla abrasione del cinturino	√				3
7.11	Sistemi di apertura a sgancio rapido	√				3
7.11.1						
7.11.2						
7.11.3						
6.16	Bande riflettenti	√				4
Fotografie del campione						5

Il dispositivo sottoposto alle prescrizioni, verifiche e prove risponde alla descrizione riportata nella scheda informativa n° FF324-2/17/00 del costruttore.

CONCLUSIONI

A seguito dell'esame della documentazione presentata dalla fabbrica costruttrice e dei risultati delle prove effettuate, presso il Laboratorio Newton S.r.l. sito in Mazzo di Rho (MI), si dichiara che il dispositivo sopra indicato risponde alla normativa vigente all'atto della presentazione della domanda e se ne attesta l'idoneità alla omologazione del tipo.

Ai fini della immissione dei dispositivi nel mercato, il casco deve essere sottoposto alle verifiche e prove previste al paragrafo 9 del Reg. ECE/ONU 22/05.

Il Rappresentante del Ministero delle Infrastrutture e dei Trasporti non si assume nessuna responsabilità per quanto riguarda i materiali costruttivi né sulle dimensioni delle varie parti non specificate nel presente verbale e/o scheda tecnica e/o disegni allegati.

Milano, 11.01.2018

Il Responsabile del procedimento
(Funzionario Tecnico Angela MARFUGGI)

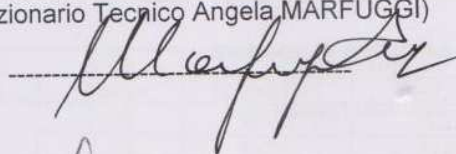

Il Direttore del C.P.A. di Milano
(Ing. Henry Del Greco)



Allegati:

- Scheda informativa e disegni

Allegato 1 **RISPONDEZZA ALLE PRESCRIZIONI GENERALI CASCO**

§ Rif.

6.	PRESCRIZIONI GENERALI	Conforme	Non Conforme	Non Ricorre
6.1	Calotta dura	<input checked="" type="checkbox"/>	<input type="checkbox"/>	
	Mezzo assorbimento d'urto	<input checked="" type="checkbox"/>	<input type="checkbox"/>	
	Sistema di tenuta	<input checked="" type="checkbox"/>	<input type="checkbox"/>	
6.2	Protezione Mascellare			
	P <input type="checkbox"/> J <input type="checkbox"/> NP <input type="checkbox"/> P/J <input checked="" type="checkbox"/>			
6.3	Dispositivi accessori	<input checked="" type="checkbox"/>	<input type="checkbox"/>	<input type="checkbox"/>
6.4.1	Copertura di protezione calotta	<input checked="" type="checkbox"/>	<input type="checkbox"/>	
6.4.2	Cilindro nuca	<input checked="" type="checkbox"/>	<input type="checkbox"/>	
6.4.3	Imbottitura di protezione	<input checked="" type="checkbox"/>	<input type="checkbox"/>	
6.5	Curvature esterne – Facoltà auditive	<input checked="" type="checkbox"/>	<input type="checkbox"/>	
6.6	Sporgenze (> 2 mm)	<input checked="" type="checkbox"/>	<input type="checkbox"/>	
6.7	Raggio curvatura sporgenze	<input checked="" type="checkbox"/>	<input type="checkbox"/>	
6.8	Interno casco	<input checked="" type="checkbox"/>	<input type="checkbox"/>	
6.9	Assemblaggio elementi del casco	<input checked="" type="checkbox"/>	<input type="checkbox"/>	
6.10	Protezione contro l'abrasione	<input checked="" type="checkbox"/>	<input type="checkbox"/>	
6.11	Sistema di tenuta			
6.11.1	Larghezza cinturino (≥ 20 mm)	<input checked="" type="checkbox"/>	<input type="checkbox"/>	<input type="checkbox"/>
6.11.3	Sistema di regolazione	<input checked="" type="checkbox"/>	<input type="checkbox"/>	
6.11.4	Parti rigide	<input checked="" type="checkbox"/>	<input type="checkbox"/>	
6.11.5	Fibbie "Doppia-D" o "Rullo"	<input checked="" type="checkbox"/>	<input type="checkbox"/>	<input type="checkbox"/>
6.11.6	Linguetta di apertura	<input checked="" type="checkbox"/>	<input type="checkbox"/>	<input type="checkbox"/>
6.11.7	Sgancio rapido	<input checked="" type="checkbox"/>	<input type="checkbox"/>	<input type="checkbox"/>
6.11.8	Verificato con prove §7.3, §7.6 e §7.7	<input checked="" type="checkbox"/>	<input type="checkbox"/>	
6.11.9	Prevenzione uso scorretto della fibbia	<input checked="" type="checkbox"/>	<input type="checkbox"/>	
6.12	Verifica caratteristiche materiale (*)	<input checked="" type="checkbox"/>	<input type="checkbox"/>	
6.13	Verifica rottura casco	<input checked="" type="checkbox"/>	<input type="checkbox"/>	
6.14	Caratteristiche visibilità periferica			
6.14.3.1	campo visuale orizzontale ($\geq 105^\circ$)	<input checked="" type="checkbox"/>	<input type="checkbox"/>	
6.14.3.2	campo visuale verso l'alto ($\geq 7^\circ$)	<input checked="" type="checkbox"/>	<input type="checkbox"/>	
6.14.3.3	campo visuale verso il basso ($\geq 45^\circ$)	<input checked="" type="checkbox"/>	<input type="checkbox"/>	

(*) Vedi dichiarazione della casa costruttrice allegata su scheda Informativa FF324-2/17/00.

Allegato 2 pg.1 **PROVA ASSORBIMENTO URTO****§7.3 Assorbimento d'urto**

CASCO tg: 65/66 (XXXL)

Numero Casco	Falsa Testa	Punto Impatto	Tipo Incudine	Condiz. Solv. +	Velocità (m/s)		Valori d'Urto		
					Prevista	Effettiva	HIC(<2400)	g(<275)	
1	62	B	PIATTA	Amb.	7,5		7,58	1756	207
		X				7,53	1312	207	
		P				7,58	1637	213	
		R				7,55	1564	212	
						7,55	1123	155	
2	62	B	KERB.	Amb.	7,5		7,55	853	161
		X				7,58	1182	159	
		P				7,55	1137	172	
		R				7,53	1664	209	
						7,55	1379	205	
3	62	B	PIATTA	-20°C	7,5		7,58	1621	219
		X				7,55	1628	229	
		P				7,55	1006	247	
		R				5,5	7,55	1098	153
		S			7,55	995	181		
4	62	B	KERB	+50°C.	7,5		7,58	1137	163
		X				7,58	1208	186	
		P				7,58	1343	237	
		R				7,58	821	154	
						7,58	1428	197	
5	62	B	KERB	UV+H ₂ O	7,5		7,58	1428	197
		X	KERB			7,55	1590	202	
		P	PIATTA						
		R	PIATTA						

CASCO tg: 65/66 (XXXL) Configurazione Jet

Numero Casco	Falsa Testa	Punto Impatto	Tipo Incudine	Condiz. Solv. +	Velocità (m/s)		Valori d'Urto		
					Prevista	Effettiva	HIC(<2400)	g(<275)	
6	62	B	PIATTA	-20°C	7,5		7,53	694	122
		X	PIATTA			7,55	1170	186	
		P	PIATTA			7,58	2199	261	
		R	PIATTA			7,58	1707	204	
		S	PIATTA			5,5	//	//	//
7	62	B	KERB	+50°C.	7,5		7,53	483	96
		X	KERB			7,55	970	171	
		P	KERB			7,58	1141	159	
		R	KERB			7,55	1132	173	

CASCO tg: 63/64 (XXL)

Numero Casco	Falsa Testa	Punto Impatto	Tipo Incudine	Condiz. Solv. +	Velocità (m/s)		Valori d'Urto		
					Prevista	Effettiva	HIC(<2400)	g(<275)	
8	62	B	PIATTA	-20°C	7,5		7,58	1630	207
		X	PIATTA			7,58	1439	215	
		P	KERB			7,58	1201	169	
		R	KERB			7,58	1290	214	
		S	PIATTA			5,5	5,53	686	190
9	62	B	KERB	+50°C.	7,5		7,58	1202	176
		X	KERB			7,55	1043	181	
		P	PIATTA			7,58	1680	207	
		R	PIATTA			7,58	1646	215	

Allegato 2 pg.2 **PROVA ASSORBIMENTO URTO**

CASCO tg: 61/62(XL)

Numero Casco	Falsa Testa	Punto Impatto	Tipo Incudine	Condiz. Solv. +	Velocità (m/s)		Valori d'Urto		
					Prevista	Effettiva	HIC(<2400)	g(<275)	
10	62	B	KERB	-20°C	7,5		7,58	1201	170
		X	KERB			7,55	697	128	
		P	PIATTA			7,60	1495	189	
		R	PIATTA			7,58	1466	198	
		S	PIATTA			5,5	5,53	903	202
11	62	B	PIATTA	+50°C.	7,5		7,58	1625	200
		X	PIATTA			7,55	1283	204	
		P	KERB			7,60	1331	233	
		R	KERB			7,55	1155	203	

CASCO tg: 59/60(L)

Numero Casco	Falsa Testa	Punto Impatto	Tipo Incudine	Condiz. Solv. +	Velocità (m/s)		Valori d'Urto		
					Prevista	Effettiva	HIC(<2400)	g(<275)	
12	60	B	PIATTA	Amb.	7,5		7,53	2032	232
		X				7,55	1422	208	
		P				7,60	2045	258	
		R				7,55	1340	187	
13	60	B	KERB.	Amb.	7,5		7,55	1510	244
		X				7,55	1138	179	
		P				7,58	1090	167	
		R				7,55	1187	196	
14	60	B	PIATTA	-20°C	7,5		7,58	2184	241
		X				7,55	1627	222	
		P				7,58	2190	267	
		R				7,58	1379	193	
		S			5,5	5,56	885	215	
15	60	B	KERB	+50°C.	7,5		7,58	1357	195
		X				7,58	837	164	
		P				7,58	1243	167	
		R				7,58	1145	186	
16	60	B	KERB	UV+H ₂ O	7,5		7,53	1508	229
		X	KERB			7,55	876	169	
		P	PIATTA			7,58	2180	255	
		R	PIATTA			7,58	1378	191	

CASCO tg: 59/60 (L) Configurazione Jet

Numero Casco	Falsa Testa	Punto Impatto	Tipo Incudine	Condiz. Solv. +	Velocità (m/s)		Valori d'Urto		
					Prevista	Effettiva	HIC(<2400)	g(<275)	
17	60	B	PIATTA	-20°C	7,5		7,53	892	146
		X	PIATTA			7,55	1286	204	
		P	PIATTA			7,55	2315	271	
		R	PIATTA			7,58	1500	205	
		S	PIATTA		5,5	//	//	//	
18	60	B	KERB	+50°C.	7,5		7,51	714	121
		X	KERB			7,58	807	156	
		P	KERB			7,60	1305	185	
		R	KERB			7,58	1123	179	

Allegato 2 pg.3 **PROVA ASSORBIMENTO URTO**

CASCO tg: 57/58(M)

Numero Casco	Falsa Testa	Punto Impatto	Tipo Incudine	Condiz. Solv. +	Velocità (m/s)		Valori d'Urto	
					Prevista	Effettiva	HIC(<2400)	g(<275)
19	57	B	PIATTA	-20°C	7,5	7,51	2214	240
		X	PIATTA			7,55	1459	205
		P	KERB			7,58	1323	178
		R	KERB			7,53	1235	165
		S	PIATTA			5,5	5,54	968
20	57	B	KERB	+50°C.	7,5	7,53	1327	172
		X	KERB			7,55	875	168
		P	PIATTA			7,55	1969	241
		R	PIATTA			7,58	1441	189

CASCO tg: 55/56 (S)

Numero Casco	Falsa Testa	Punto Impatto	Tipo Incudine	Condiz. Solv. +	Velocità (m/s)		Valori d'Urto	
					Prevista	Effettiva	HIC(<2400)	g(<275)
21	54	B	PIATTA	Amb.	7,5	7,55	1850	211
		X				7,55	1465	210
		P				7,58	1722	217
		R				7,58	1631	193
22	54	B	KERB.	Amb.	7,5	7,55	1291	175
		X				7,55	824	148
		P				7,58	1416	210
		R				7,55	1162	171
23	54	B	PIATTA	-20°C	7,5	7,55	1829	226
		X				7,58	1329	192
		P				7,58	1786	220
		R				7,55	1784	207
		S			5,5	5,54	1091	244
24	54	B	KERB	+50°C.	7,5	7,55	1296	180
		X				7,55	784	142
		P				7,58	1250	178
		R				7,58	1128	167
25	54	B	KERB	UV+H ₂ O	7,5	7,55	1246	159
		X	KERB			7,58	777	142
		P	PIATTA			7,58	1698	220
		R	PIATTA			7,55	1911	193

CASCO tg: 55/56 (S) Configurazione Jet

Numero Casco	Falsa Testa	Punto Impatto	Tipo Incudine	Condiz. Solv. +	Velocità (m/s)		Valori d'Urto	
					Prevista	Effettiva	HIC(<2400)	g(<275)
26	54	B	PIATTA	-20°C	7,5	7,53	918	142
		X	PIATTA			7,55	1108	169
		P	PIATTA			7,55	1950	230
		R	PIATTA			7,55	1799	203
		S	PIATTA		5,5	//	//	//
27	54	B	KERB	+50°C.	7,5	7,55	807	124
		X	KERB			7,55	580	122
		P	KERB			7,55	1116	169
		R	KERB			7,55	1104	160

Allegato 2 pg.4 **PROVA ASSORBIMENTO URTO**

CASCO tg: 53/54 (XS)

Numero Casco	Falsa Testa	Punto Impatto	Tipo Incudine	Condiz. Solv. +	Velocità (m/s)		Valori d'Urto	
					Prevista	Effettiva	HIC(<2400)	g(<275)
28	54	B	KERB	-20°C	7,5	7,55	1263	164
		X	KERB			7,58	733	148
		P	PIATTA			7,58	1740	218
		R	PIATTA			7,55	1895	214
		S	PIATTA			5,5	5,53	491
29	54	B	PIATTA	+50°C.	7,5	7,55	1983	222
		X	PIATTA			7,55	1411	194
		P	KERB			7,58	1322	179
		R	KERB			7,55	1158	163

CASCO tg: 51/52 (XXS)

Numero Casco	Falsa Testa	Punto Impatto	Tipo Incudine	Condiz. Solv. +	Velocità (m/s)		Valori d'Urto	
					Prevista	Effettiva	HIC(<2400)	g(<275)
30	50	B	PIATTA	-20°C	7,5	7,53	2221	244
		X	KERB			7,55	1233	186
		P	PIATTA			7,58	1938	220
		R	KERB			7,58	1506	180
		S	PIATTA			5,5	5,52	491
31	50	B	KERB	+50°C.	7,5	7,58	1342	162
		X	PIATTA			7,55	1397	188
		P	KERB			7,55	1288	180
		R	PIATTA			7,58	2182	227

Allegato 3 PROVE DELLE SPORGENZE E ATTRITO DELLA SUPERFICIE DELLA CALOTTA, RIGIDITA' e SISTEMA DI TENUTA.
§7.4.2.1.3.1. Prova delle sporgenze (metodo B) Conforme Non Conforme

Descrizione punto di test	Conforme	Non Conforme	Note
Frontino	√		
Attacco lato mentoniera	√		

§7.4.2.1.3.2. Attrito della superficie esterna: Conforme Non Conforme

§7.5 Prova di rigidità

Casco			Direzione Sollecitazione	Carico e deformazione		
N°	Falsa testa	Tg.		Iniziale [30N]	Massima [630N] (≤ 40 mm)	Finale [30N] (≤ 15 mm)
32	62	XXXL	Longitudinale	0 mm	19 mm	2 mm
33	62	XXXL	Trasversale	0 mm	14 mm	2 mm
34	60	L	Longitudinale	0 mm	10 mm	2 mm
35	60	L	Trasversale	0 mm	11 mm	3 mm
36	54	S	Longitudinale	0 mm	24 mm	4 mm
37	54	S	Trasversale	0 mm	17 mm	3 mm

§7.6 e §7.7 Prova dinamica del sistema di ritenuta e di scalzamento

Casco			Allungamento		Casco			Scalzamento	Note
N°	Falsa testa	Tg.	Dinamico (≤ 35 mm)	Residuo (≤ 25 mm)	N°	Falsa testa	Tg.	Rotazione (≤ 30°)	
38	62	XL	23	11	39	62	XL	25	Anelli
40	62	XL	24	14	41	62	XL	17	Micrometrica mod. N.10
42	57	M	25	11	43	57	M	26	Anelli
44	57	M	23	13	45	57	M	29	Micrometrica mod. N.10
46	52	XXS	25	9	47	52	XXS	17	Anelli
48	52	XXS	24	10	49	52	XXS	17	Micrometrica mod. N.10

Fibbia e cinturino Conforme Non Conforme Non Ricorre

§ 7.9	Microscorrimento del cinturino (≤10 mm) Valore rilevato 4 mm	<input checked="" type="checkbox"/>	<input type="checkbox"/>	<input type="checkbox"/>
§ 7.10	Resistenza all'abrasione del cinturino	<input checked="" type="checkbox"/>	<input type="checkbox"/>	<input type="checkbox"/>
§ 7.11	Sistemi di apertura a sgancio rapido			
§ 7.11.1	Apertura accidentale a pressione	<input checked="" type="checkbox"/>	<input type="checkbox"/>	<input type="checkbox"/>
§ 7.11.2	Facilità di apertura (Forza max ≤ 30 N*) (*): ≤ 60 N per sistemi integrati nella calotta	<input checked="" type="checkbox"/>	<input type="checkbox"/>	<input type="checkbox"/>
§ 7.11.3	Resistenza a fatica del meccanismo di sgancio	<input checked="" type="checkbox"/>	<input type="checkbox"/>	<input type="checkbox"/>

Osservazioni:

Allegato 4 **PRESCRIZIONI GENERALI E PROVE BANDE RETRORIFLETTENTI****MATERIALE**

Tipo materiale 3M 13050 Scotchlite Reflective Sheeting

Le bande verranno applicate sui caschi destinati a quei paesi che ne fanno esplicita richiesta.

§ 6.16 Bande rifrangenti6.16.1 Prescrizioni generali Conforme Non Conforme6.16.2 Parti riflettenti Conforme Non ConformeArea superficie retroriflettente ($\geq 18 \text{ cm}^2$) Si No

E' possibile iscrivere un:

- cerchio ($\varnothing 40 \text{ mm}$)	<input type="checkbox"/> Si	<input checked="" type="checkbox"/> No
- un rettangolo (largh. $\geq 20 \text{ mm}$ e Sup. $\geq 12,5 \text{ cm}^2$)	<input checked="" type="checkbox"/> Si	<input type="checkbox"/> No

6.16.3 Prove colorimetriche (*) Conforme Non ConformeValori coordinate tricromatiche: **X= 0,4217** **Y= 0,4061**

Limiti verso il:

Blu	($x \geq 0,310$)
Giallo	($x \leq 0,500$)
Verde	($y \leq 0,150 + 0,640x$)
Verde	($y \leq 0,440$)
Viola	($y \geq 0,050 + 0,750x$)
Rosso	($y \geq 0,382$)

6.16.4 Prove fotometriche (*) Conforme Non ConformeValori del coefficiente di intensità luminosa con angolo di divergenza di 20° :

Angolo di illuminazione:

0°	($\geq 100 \text{ mcd/lx}$)	118,5
20°	($\geq 60 \text{ mcd/lx}$)	85,7
40°	($\geq 25 \text{ mcd/lx}$)	37,1

6.16.5 Resistenza agli agenti esterni Conforme Non Conforme6.16.6 Compatibilità del materiale adesivo Conforme Non Conforme

(*) Vedi dichiarazione allegata del costruttore e verbale del Centro Prove Autoveicoli di Milano n° 00296/CPA-MI/2011 del 31.03.2011

Osservazioni: //

Allegato 5 pag. 1 **FOTO DEL DISPOSITIVO**

Configurazione P - PROTETTIVA



Vista Frontale



Vista Posteriore

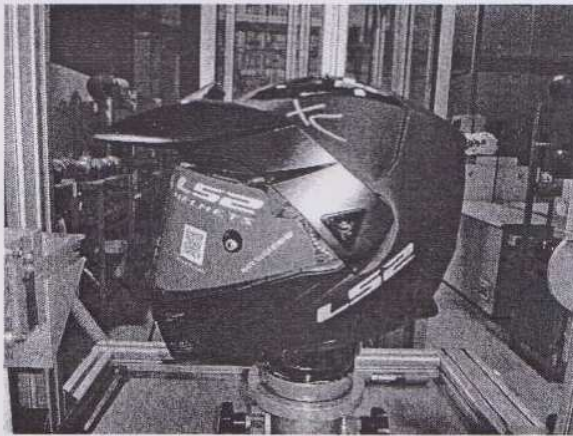

Vista laterale sinistra

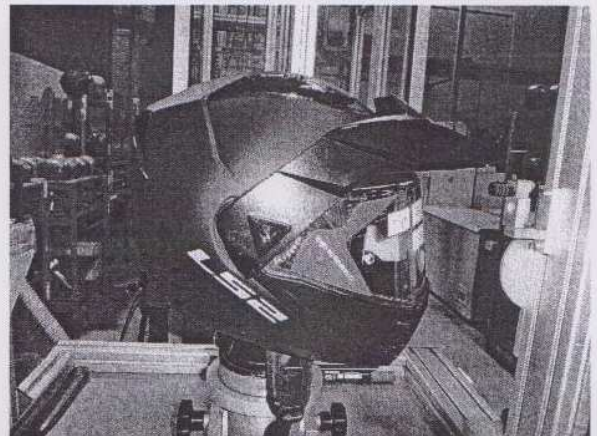

Vista laterale destra

Allegato 5 pag. 2 **FOTO DEL DISPOSITIVO**

Configurazione J - JET

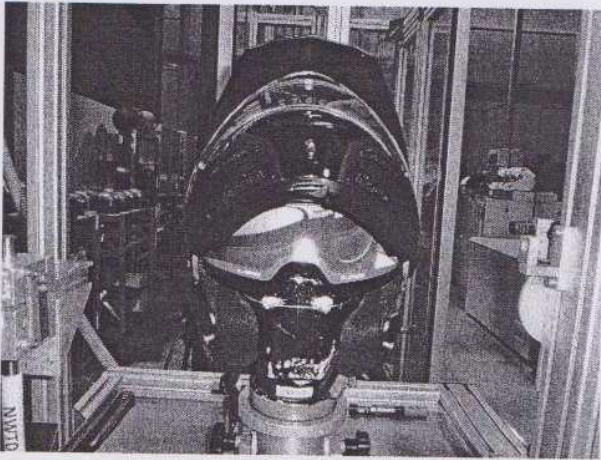

Vista Frontale

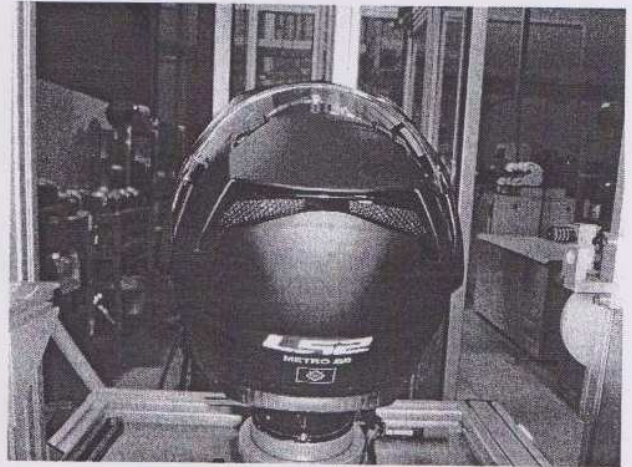

Vista Posteriore

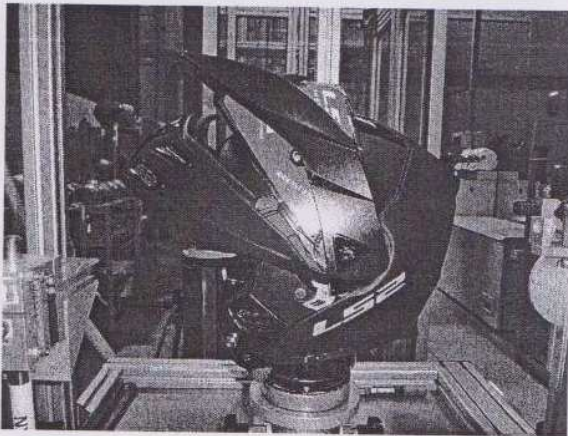

Vista laterale sinistra

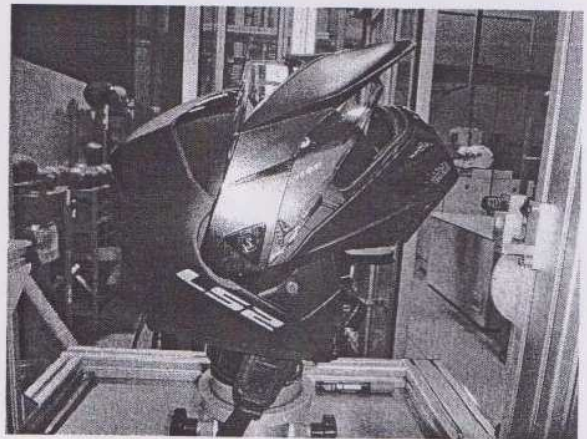

Vista laterale destra

JIANGMEN PENGCHENG HELMETS LTD

NO.01-7, DONGSHENG ROAD,
GONGHE TOWN, HESHAN CITY,
GIANGDONG PROV. 52928
P.R. CHINA

Scheda Informativa redatta sulla base del Regolamento ECE/ONU n° 22 emendamento 05	Scheda Informativa n° FF324-2/17/00
Casco: FF324-2	04.09.2017

Helmet type/casco tipo: **FF324-2;**

Denominazioni Commerciali / Commercial name: **FF324-D;METRO EVO ;FF324-C; FF324-A;
METRO V3;METRO**

Trade mark/marchio di fabbrica o di commercio: **MHR, HARLEY DAVIDSON , LS2, TAKAI,
SPYDER, HELD, A-PRO, SPARX, FULMER, KENNY, NOX, VENOM, SPEED AND STRENGTH,
JOE ROCKET, SPEEDWAY, EXKLUSIV, DEXTER, DROXX, ROCC, NEXO, AXO, NITRO, FFM,
TAKACHI, STELS, S-LINE, BAYARD, G-MAC, FLINT, TRIK MOTO, SPIRIT, X-VINCE, SHAFT-
PRO, KONTROL, SMOOK, IXS, FIRST RACING, RXA, VOSS, ZOX, CX RACING, BOX,
SWIFT,SYKO, CMS, MAC, OXFORD, BiLT, SEDICI, SKULLY, XPLOER, DIEFFE,
STREET&STEEL, TUZO, TEXX, LIFESTYLE, KOJI,HARLEY DAVIDSON , GUN , SHELL**

Weight/peso: **XXXL-XL:1750 ± 50g ;
L-M :1650 ± 50g;
S-XXS:1600 ± 50g**

Size range/gamma taglie: **XXXL 65/66-XXL 63/64-XL 61/62 L 59/60-M 57/58
S 55/56-XS 53/54-XXS 51/52**

Size/cm	External shell	EPS Liner	EPS Thickness (mm)	EPS (Protective padding)Density (Main +Ear + Middle) (Kg/m ³)	EPS (Protective padding)Weight (Main +Ear + Middle) (grams)	Pudding comfort Thickness (mm)
XXS 51/52	S	XXS	30-35	50+40+85	105.2+56.1+7.2	16
XS 53/54	S	XS	30-35	55+40+85	115.7+56.1+7.2	12
S 55/56	S	S	30-35	55+40+85	115.7+56.1+7.2	8
M 57/58	M	M	30-35	55+65+85	123.9+76.2+7.2	12
L 59/60	M	L	30-35	65+80+85	146.4+104.4+7.2	8
XL 61/62	XL	XL	30-35	60+80+85	162.5+104.4+7.2	12
XXL 63/64	XL	XXL	30-35	60+80+85	162.5+104.4+7.2	8
XXXL 65/66	XL	XXXL	30-35	60+80+85	162.5+104.4+7.2	7

External shell/calotta esterna: **ABS /3 shells/Tripla calotta
Thickness/spessore:2.5mm ±0.5mm (all shells same)**

Liner/Imbottitura di protezione: **EPS /Expanded polystyrene**

Peak/frontino: **Nylon**

Comfort pudding/ Imbottitura di protezione: **Expanded polyuretane + syntethic textile/poliuretano
Espanso e tessuto sintetico**

Chin rest/Mentoniera: **Expanded Polystyrene+Polyurethane Double code:P/J
EPS e poliuretano doppio codice:P/J**

JIANGMEN PENGCHENG HELMETS LTD

NO.01-7, DONGSHENG ROAD,
GONGHE TOWN, HESHAN CITY,
GIANGDONG PROV. 52928
P.R. CHINA

Scheda Informativa redatta sulla base del Regolamento ECE/ONU n° 22 emendamento 05	Scheda Informativa n° FF324-2/17/00
Casco: FF324-2	04.09.2017

Buckle/Fibbia: 1)Anelli doppia D in acciaio / *Double-D ring in steel*
2)Micrometrica mod. No.10 Acciaio e policarbonato/
Micrometric buckle No.10 Polycarbonate and steel
3)Micrometrica mod. No.17 Acciaio e policarbonato/
~~*Micrometric buckle No.17 Polycarbonate and steel*~~

Chin strap/Cinturino: Nylon 22 mm (Micrometrica) +25 mm (Anelli)
Rivets/Rivetti: Stainless steel/ *Acciaio*
Anchorage/Staffe: Stainless steel/ *Acciaio*

Visor/ Visiera: FF-MHR-77 (E1 05300507) + approval certificate

Accessori/Accessories: Visierino parasole / *sun visor*

Reflective stickers/bande rifrangenti: 3M 13050 Scotchlite Reflective Sheeting

(The reflective stickers on helmets will be applied for countries that require it explicitly)/
(Le bande rifrangenti verranno applicate sui caschi destinati a quei paesi che ne fanno esplicita richiesta)

Declaration: The characteristics of the materials used in manufacture of the helmet don't suffer alterations following the normal use of the helmet. For the part in contact with the skin it is used materials that don't cause allergy and are transpiring. These materials don't suffer from the variations due to sweating or to products used for the personal hygiene. These materials don't cause dermal problems.

Idoneità dei materiali:

I materiali utilizzati nella fabbricazione dei caschi sono adeguati all'uso e , in particolare per quelli a contatto con la pelle, sono noti per non subire modifiche per effetto del sudore o prodotti per l'igiene personale e per non causare problemi dermatologici. Sarà nostra cura comunicare tutte le variazioni che si effettuano e verificare l'adeguatezza dei materiali impiegati per la produzione del casco.

BRAND AND LABELS/POSIZIONAMENTO DELLE MARCATURE OBBLIGATORIE

Trade mark/ Marchio di fabbrica o di commercio: on frontal and rear external shell / *Sulla calotta esterna marchio posizionato in fronte e dietro*

Size label/ Indicazione delle misure: Adhesive label on the rear external shell/ *Sul retro del casco mediante una etichetta adesiva*

Approval label/ Etichetta omologativa: on the chin strap/ *Cucita al sistema di ritenuta*

Weight /Massa del casco: Adhesive label on the rear external shell/ *Sul retro accanto alla taglia*



JIANGMEN PENGCHENG HELMETS LTD

Ing. Massimo Giudici
Technical person Responsible

INFORMATION DOCUMENT

No.: R22-FF324-2-00

LS2

Jiangmen Pengcheng Helmets Co., Ltd.

TYPE: FF324-2

Protective helmet with visor
pursuant to

Regulation No. 22

**MINISTERO DELLE INFRASTRUTTURE
E DEI TRASPORTI**

**DIPARTIMENTO DEI TRASPORTI TERRESTRI
CENTRO PROVE AUTOVEICOLI - MILANO
OMOLOGATO**

CON ATTO N. E3052882/P-5
DEL 11-01-2018

UNIFORM PROVISIONS CONCERNING THE APPROVAL OF
PROTECTIVE HELMETS AND THEIR VISORS FOR DRIVERS AND
PASSENGERS OF MOTORCYCLES AND MOPEDS

Signature of a responsible person:

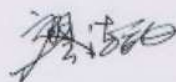

Date: 16.03.2017

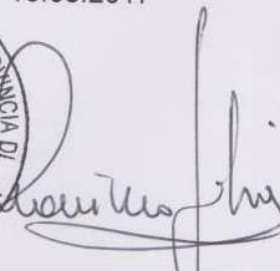

INFORMATION DOCUMENT

No.: R22-FF324-2-00

LS2

Jiangmen Pengcheng Helmets Co., Ltd.

TYPE: FF324-2

Protective helmet with visor
pursuant to

Regulation No. 22

UNIFORM PROVISIONS CONCERNING THE APPROVAL OF
PROTECTIVE HELMETS AND THEIR VISORS FOR DRIVERS AND
PASSENGERS OF MOTORCYCLES AND MOPEDS

Signature of a responsible person:

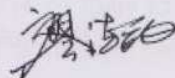

Date: 16.03.2017



Type : FF324-2
 Manufacture : Jiangmen Pengcheng Helmets Co., Ltd.

Date: 10.03.2017

Page 2 of 29

0 GENERAL INFORMATION

- 0.1 Make (trade name of manufacturer) : MHR, HARLEY DAVIDSON , LS2, TAKAI, SPYDER, HELD, A-PRO, SPARX, FULMER, KENNY, NOX, VENOM, SPEED AND STRENGTH, JOE ROCKET, SPEEDWAY, EXKLUSIV, DEXTER, DROXX, ROCC, NEXO, AXO, NITRO, FFM, TAKACHI, STELS, S-LINE, BAYARD, G-MAC, FLINT, TRIK MOTO, SPIRIT, X-VINCE, SHAFT-PRO, KONTROL, SMOOK, IXS, FIRST RACING, RXA, VOSS, ZOX, CX RACING, BOX, SWIFT, SYKO, CMS, MAC, OXFORD, BILT, SEDICI, SKULLY, XPLORER, DIEFFE, STREET&STEEL, TUZO, TEXX, LIFESTYLE, KOJI, HARLEY DAVIDSON , GUN , SHELL
- 0.2 Type : FF324-2
- 0.2.1 Commercial description(s) : FF324-D, FF324-C, FF324-2, FF324-A, METRO EVO, METRO V3 , METRO.
- 0.3 Variants / Versions : n.a.
- 0.4 Name and address of manufacturer : Jiangmen Pengcheng Helmets Co., Ltd. Industrial Park East, Gonghe Town, Heshan City Guangdong Province, China
- 0.5 Name and address of assembly plant : Jiangmen Pengcheng Helmets Co., Ltd. Industrial Park East, Gonghe Town, Heshan City Guangdong Province, China
- 0.6 Name and address of manufacturer's authorized representative(if any) : n.a.
- 0.7 Location and method of affixing of the international approval mark : Marked in a label sewn on the retention system chin strap

1 TECHNICAL DESCRIPTION

- 1.1 Description of the helmet
 - 1.1.1 Type of helmet : full face / Open face
 - 1.1.2 Type of lower face cover : "P" protective(close the protective chin bar) / "J" none(open the protective chin bar)
 - 1.1.3 Size (cm) : XXS(51/52), XS(53/54), S(55/56), M(57/58), L(59/60), XL(61/62), XXL(63/64), XXXL(65/66)
 - 1.1.4 Drawing of the helmet : See annex 1; See annex 4
 - 1.1.5 Type(s) of visor to which may be equipped with this helmet : FF-MHR-77
- 1.2 Description of the visor : Visor type: FF-MHR-77 Approval No.: E1- 05300507
- 1.3 Description of the shell
 - 1.3.1 Material : ABS
 - 1.3.2 Manufacture method : Injection
 - 1.3.3 Ventilation : None
 - 1.3.4 Composition of the border join on the shell : PVC
 - 1.3.5 Drawing of the shell : See annex 3
- 1.4 Description of protective padding
 - 1.4.1 Composition : Expanded polystyrene



Type : FF324-2
 Manufacture : Jiangmen Pengcheng Helmets Co., Ltd.

Date: 10.03.2017

Page 3 of 29

1.4.2 Density and weight

Size (cm)	Shell size	Comfort padding thickness (Main) (mm)	EPS (Protective padding)Density (Main +Ear + Middle) (Kg/m ³)	Protective padding Thickness (mm)	EPS (Protective padding)Weight (Main +Ear + Middle) (grams)
XXS(51/52)	S	16	50+40+85	30-35	105.2+56.1+7.2
XS(53/54)	S	12	55+40+85	30-35	115.7+56.1+7.2
S(55/56)	S	8	55+40+85	30-35	115.7+56.1+7.2
M(57/58)	M	12	55+65+85	30-35	123.9+76.2+7.2
L(59/60)	M	8	65+80+85	30-35	146.4+104.4+7.2
XL(61/62)	XL	12	60+80+85	30-35	162.5+104.4+7.2
XXL(63/64)	XL	8	60+80+85	30-35	162.5+104.4+7.2
XXXL(65/66)	XL	7	60+80+85	30-35	162.5+104.4+7.2

1.4.3 Drawing of the protective padding : See annex 5

1.5 Description of comfort padding

- 1.5.1 Composition of
 Comfort padding : Compound sponge
 Comfort tissue : Nylon
 Protection of the back of the nape : Sponge, textile and leather
 Lateral packing : EPS and compound sponge
 Lower face cover : EPS and PU
- 1.5.2 Drawing of the comfort padding : See annex 6

1.6 Description of the retention system

- 1.6.1 Chin strap
 Material : Nylon
 Width : 22 mm or 25 mm
- 1.6.2 Retention system : Type 1: Double-D ring with 25mm Chin strap
 Type 2: No.10 quick release mechanism with 22mm Chin strap

1.6.3 Comfort padding of the retention system

- Composition : Leather and textile
 Thickness : 3 mm

1.6.4 Anchorage system to the shell : By means of a metallic piece fixed to the shell by rivets

1.6.5 Drawing of the retention system : See annex 7

1.7 Other Characteristics

- 1.7.1 Markings
 Make : Rear part of the shell
 Weight : Rear part of the shell
 Size : Rear part of the shell

1.7.2 Indelible marking
 How it is made : Sewing
 Position : On the chin strap

1.8 Accessories : See annex 8



Type : FF324-2
 Manufacture : Jiangmen Pengcheng Helmets Co., Ltd.

Date: 10.03.2017

Page 4 of 29

- 1.8.1 Peak : n.a.
- 1.8.2 Information for wearer
- 1.8.2.1 Text : See annex 9
- 1.8.2.2 Position : Hang on chin strap

ANNEXS

Annex 1	Drawing of the helmet	16.01.2017
Annex 2	Drawing of the Visor	16.01.2017
Annex 3	Drawing of the shell	16.01.2017
Annex 4	Drawing of the Peak	16.01.2017
Annex 5	Drawing of the protective padding	16.01.2017
Annex 6	Drawing of the comfort padding	16.01.2017
Annex 7	Drawing of the retention system	16.01.2017
Annex 8	Drawing of the accessories	16.01.2017
Annex 9	Information for wearer	16.01.2017

2-00
2017
2017
2017
2017
2017
2017
2017

INFORMATION DOCUMENT

R22-FF324-2-00

LS2

Type : FF324-2
Manufacture : Jiangmen Pengcheng Helmets Co., Ltd.

Date: 10.03.2017

Page 5 of 29

Annex 1: Drawing of the helmet

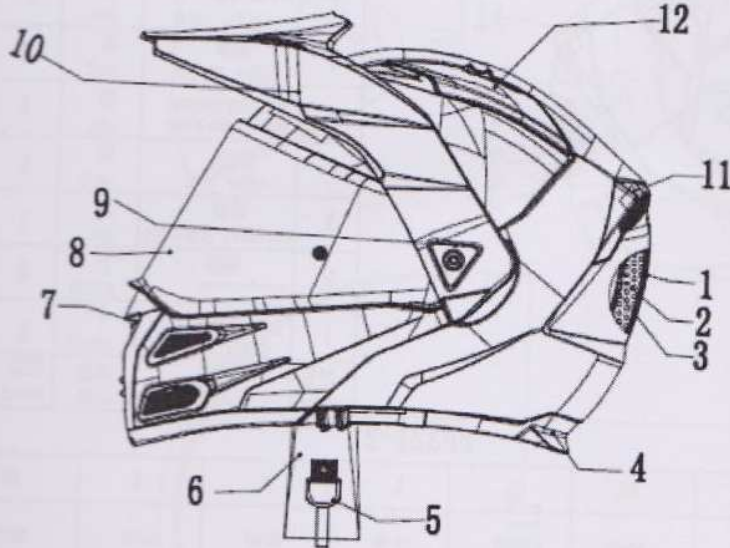

12	后风窗 back vent	个 piece	1	abs
11	前风窗 top vent	个 piece	2	abs
10	帽沿 Visor/Peak	个 piece	1	nylon
9	底座 Ratchet system	套 set	2	pon
8	镜片 visor	个 piece	1	pc
7	下巴风窗 mouth vent	套 set	1	abs
6	帽带 chin strap	条 unit	2	nylon
5	快拆扣/缓冲扣/缓冲环扣 lockin/buckle/ring	套 set	1	ss/ stainless steel
4	橡胶条 rubber ring	条 unit	1	pvc
3	内衬 comfort padding	套 set	1	nylon
2	泡沫 protective padding	个 piece	5	eps
1	壳体 Outer shell	个 piece	1	abs
序号 number	名称 name	单位 unit	数量 piece	材料 material

MODEL	FF324-2							
SIZE	XXXL	XXL	XL	L	M	S	XS	XXS
CM	66-65	64-63	62-61	60-59	58-57	56-55	54-53	52-51

技术要求
Technical requirement

1. The surface of the outshell should be smooth and bright no mottle, pinhold, bulb, drop lack of oil, disdosome of basic color.
2. Every spare parts should be fixed correctly, and not be loose, missed.



Type : FF324-2
 Manufacture : Jiangmen Pengcheng Helmets Co., Ltd.

Date: 10.03.2017

Page 6 of 29

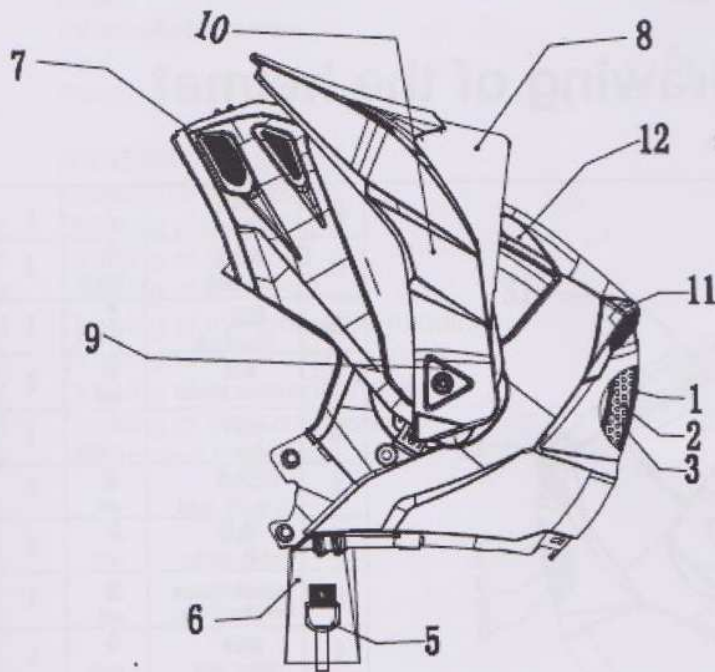

12	后风窗 back vent	个 piece	1	abs
11	前风窗 top vent	个 piece	2	abs
10	帽沿 Visor/Peak	个 piece	1	nylo
9	底座 Ratchet system	套 set	2	pon
8	镜片 visor	个 piece	1	pc
7	下巴风窗 mouth vent	套 set	1	abs
6	帽带 chin strap	条 unit	2	nylo
5	快拆扣/双平扣快环扣 buckle/Double 'V' ring	套 set	1	stainless
4	底座条 rubber ring	条 unit	1	pvc
3	内衬 comfort padding	套 set	1	nylo
2	泡沫 protective padding	个 piece	5	eps
1	壳体 Outer shell	个 piece	1	abs
序号 number	名称 name	单位 unit	数量 piece	材料 mate

MODEL	FF324-2							
SIZE	XXXL	XXL	XL	L	M	S	XS	
CM	66-65	64-63	62-61	60-59	58-57	56-55	54-53	

技术要求 Technical requirements

1. The surface of the outshell should be smooth and bright no mottle, pinhold, bulb, drop lack of oil, discolored of basic color.
2. Every spare parts should be fixed correctly, and not be loose, missed.

Annex 2: Drawing of the Visor

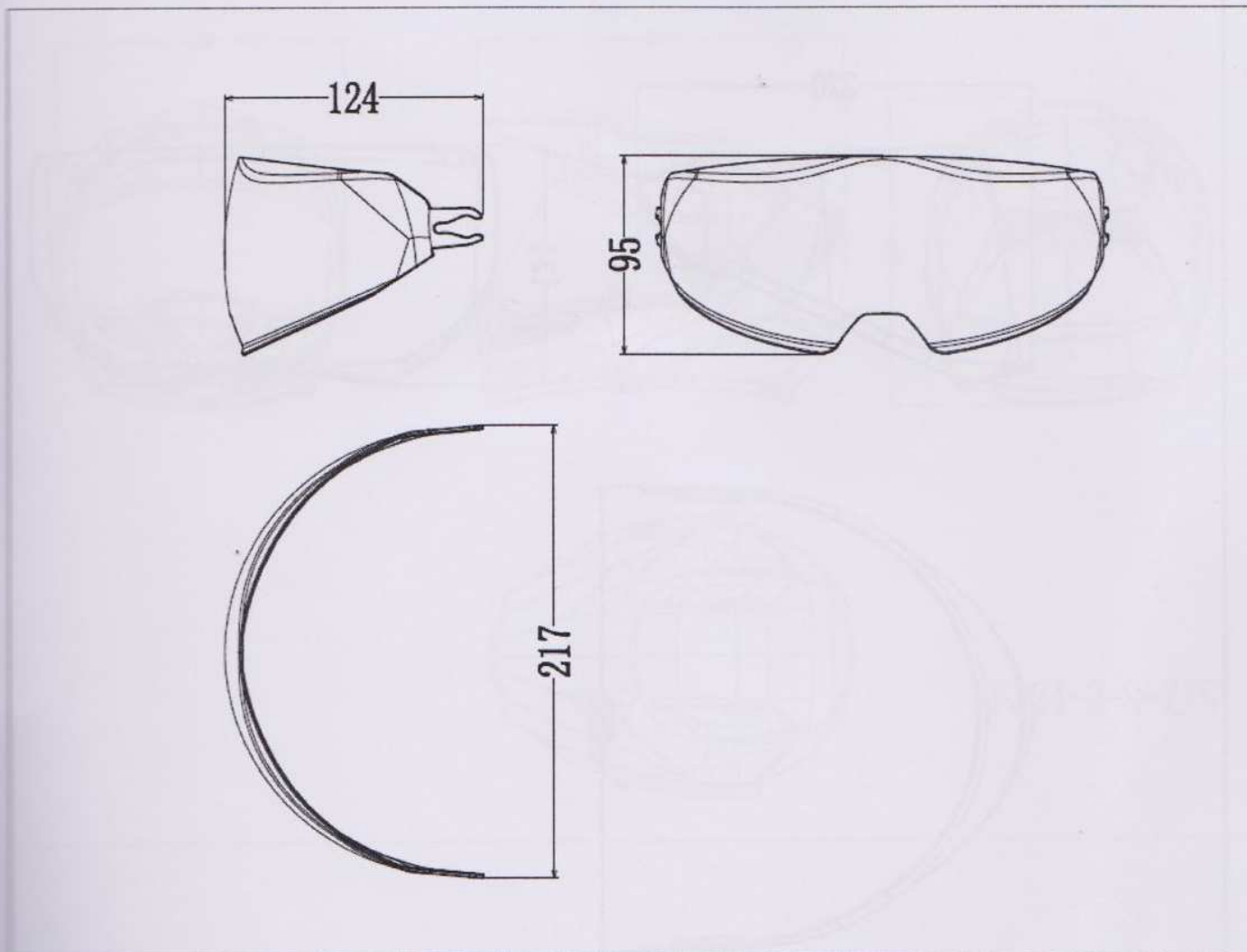

Unit: mm

Number	Name	Parameter	Number	Name	Parameter
1	Sun shade material	PC	2	thickness	1.5±0.5 mm
Description	FF324-2 sun shade		Code No.:	FF324-2.2.1	
Manufacturer:	Jiangmen Pengcheng Helmets Co., Ltd.				
Address:	Industrial Park East, Gonghe Town, Heshan City Guangdong Province, China				
Drawn by:	Xinsheng Liu	Checked by:	Xinsheng Liu	Approved by:	YouJunFeng
Date:	16.01.2017	Date:	26.02.2017	Date:	26.02.2017

INFORMATION DOCUMENT

R22-FF324-2-00

LS2

Type : FF324-2
 Manufacture : Jiangmen Pengcheng Helmets Co., Ltd.

Date: 10.03.2017

Page 8 of 29

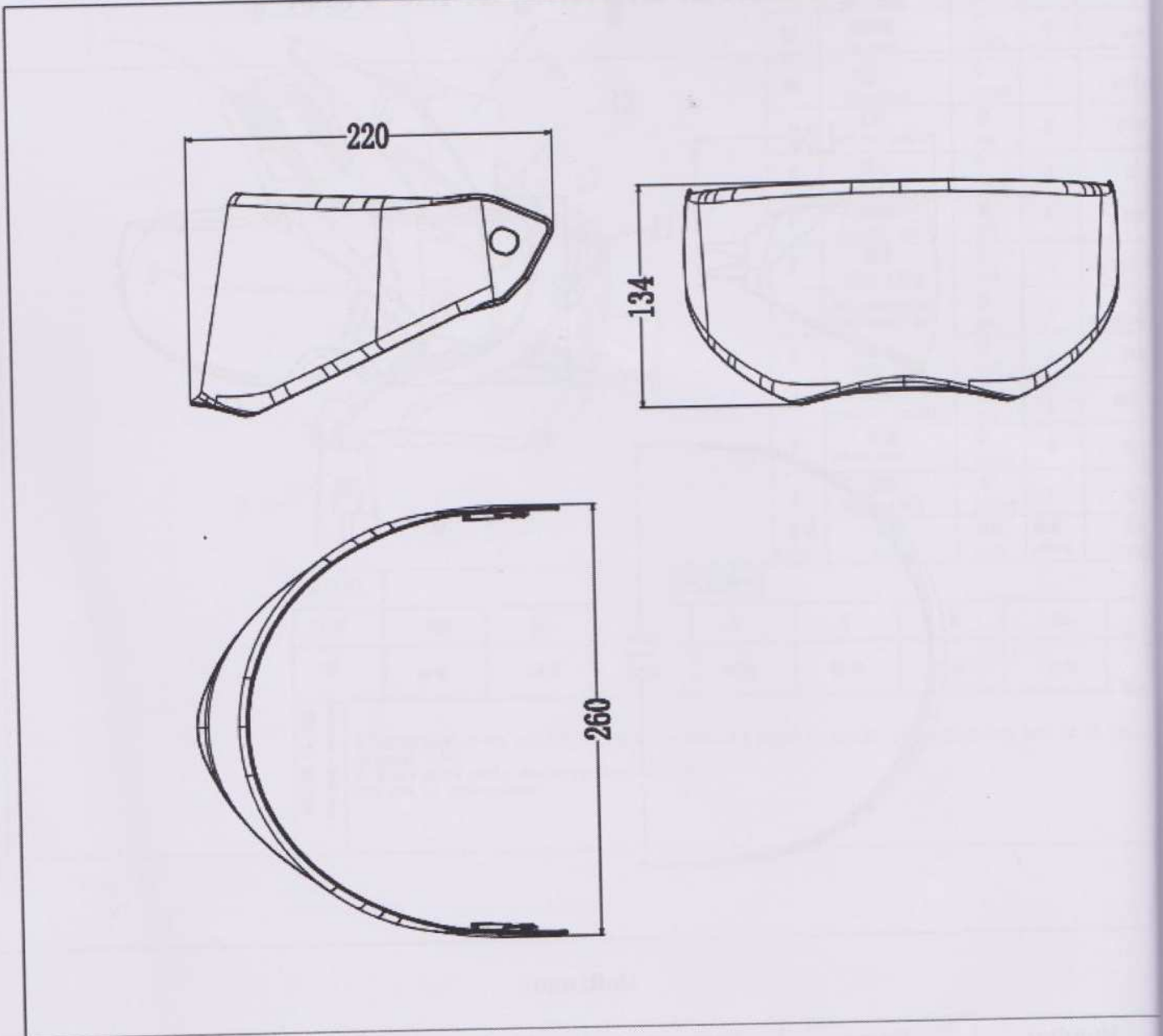

Unit: mm

Number	Name	Parameter	Number	Name	Parameter
1	Visor material	PC	2	Visor thickness	2.0±0.1 mm
Description		FF-MHR-77 Visor	Code No.:		FF-MHR-77.2.2
Manufacturer:		Jiangmen Pengcheng Helmets Co., Ltd.			
Address:		Industrial Park East, Gonghe Town, Heshan City Guangdong Province, China			
Drawn by:	ShaoHuaFu	Checked by:	ShaoHuaFu	Approved by:	YunWang
Date:	26.05.2015	Date:	02.06.2015	Date:	02.06.2015



Type : FF324-2
Manufacture : Jiangmen Pengcheng Helmets Co., Ltd.

Date: 10.03.2017

Page 9 of 29

Annex 3: Drawing of the shell

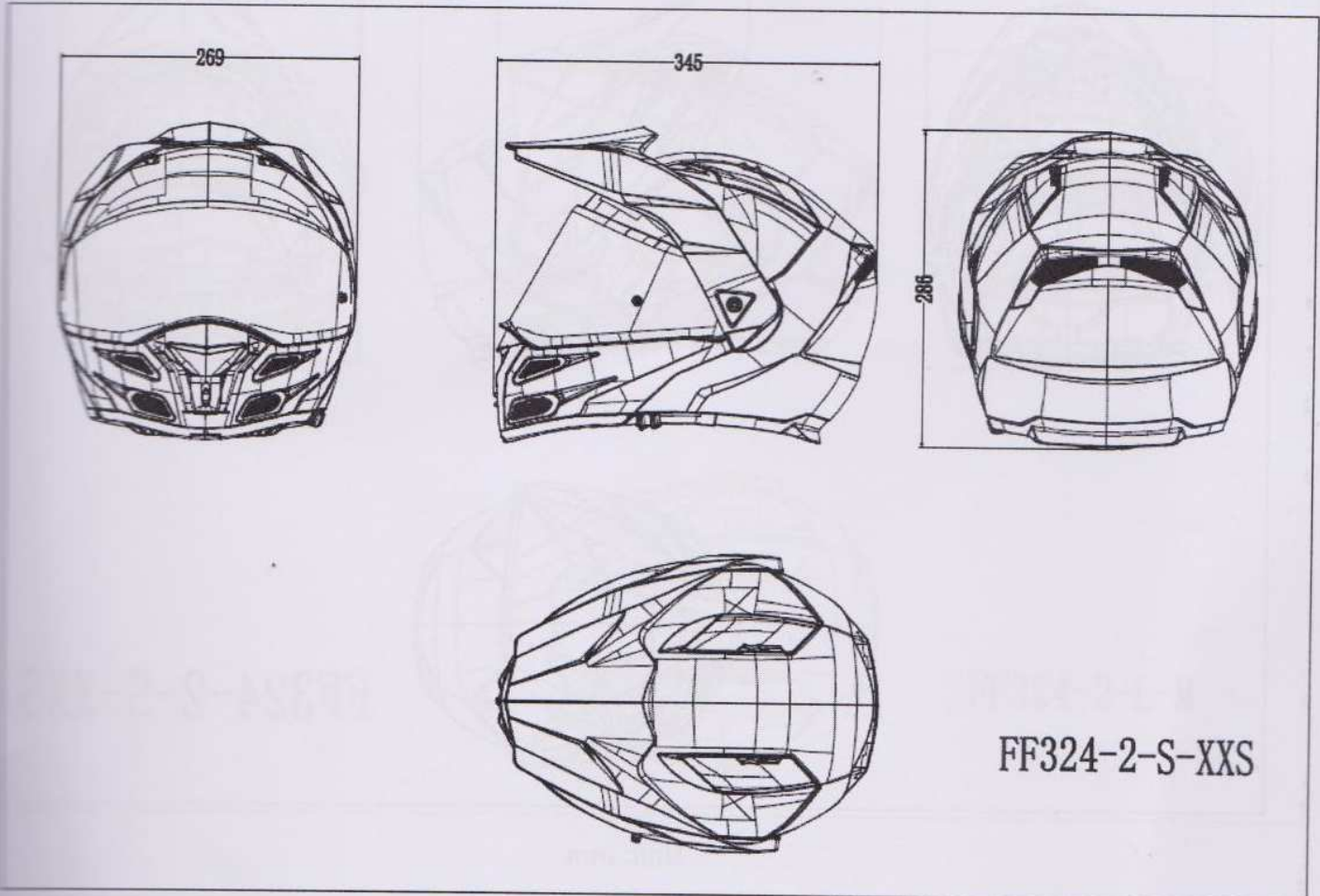

INFORMATION DOCUMENT

R22-FF324-2-00

LS2

Type : FF324-2
 Manufacture : Jiangmen Pengcheng Helmets Co., Ltd.

Date: 10.03.2017

Page 10 of 29

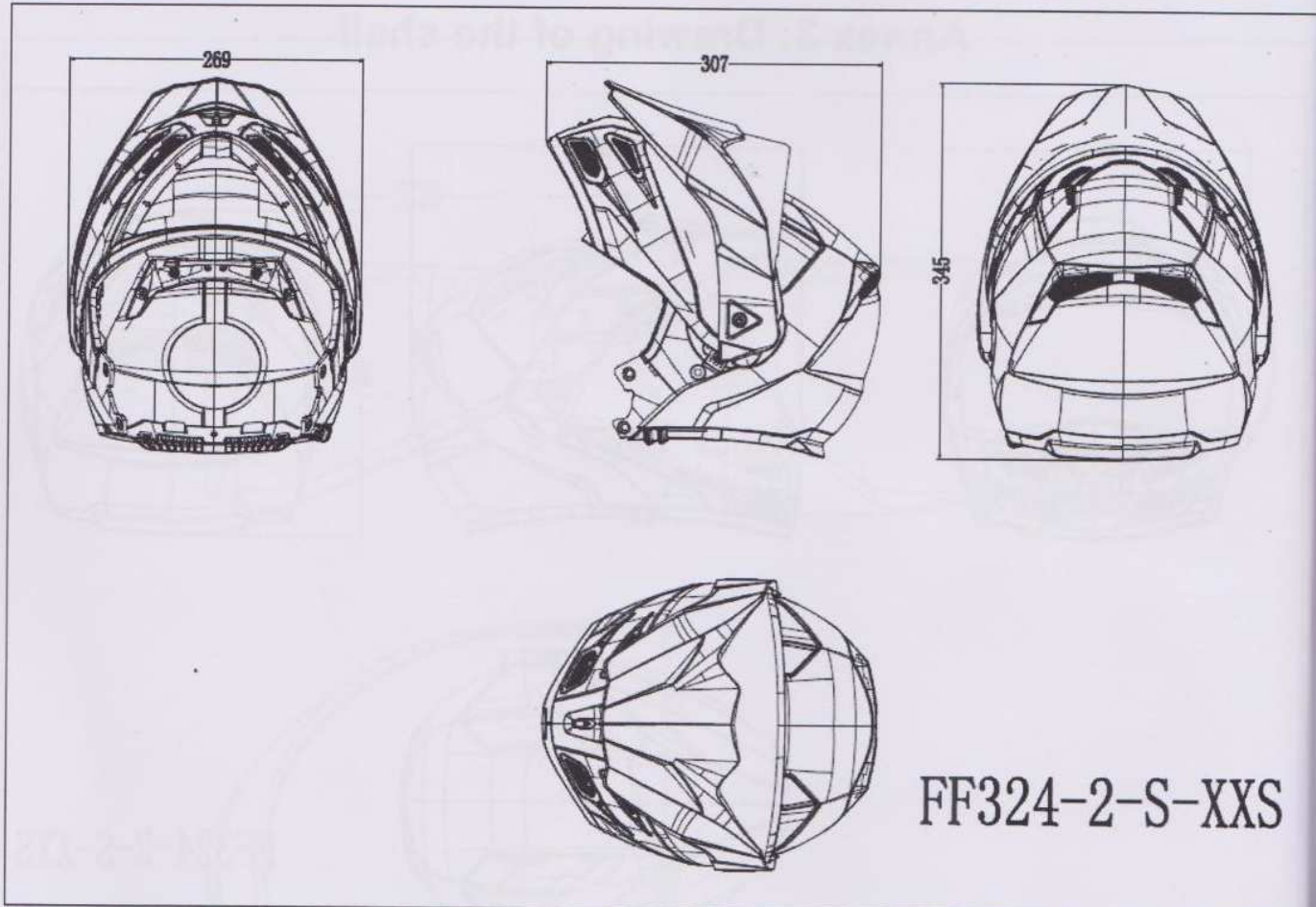

Unit: mm

Number	Name	Parameter	Number	Name	Parameter
1	Shell	ABS			
Description	FF324-2 Small Shell		Code No.:	FF324-2.3.1	
Manufacturer:	Jiangmen Pengcheng Helmets Co., Ltd.				
Address:	Industrial Park East, Gonghe Town, Heshan City Guangdong Province, China				
Drawn by:	Xinsheng Liu	Checked by:	Xinsheng Liu	Approved by:	YouJunFeng
Date:	16.01.2017	Date:	26.02.2017	Date:	26.02.2017

-00
017
29

INFORMATION DOCUMENT

R22-FF324-2-00

LS2

Type : FF324-2
Manufacture : Jiangmen Pengcheng Helmets Co., Ltd.

Date: 10.03.2017

Page 11 of 29

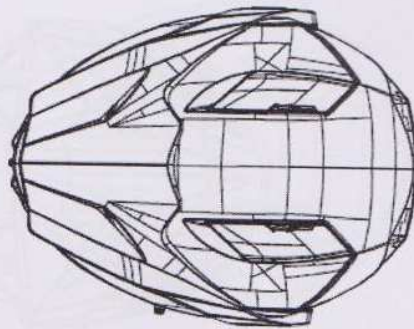
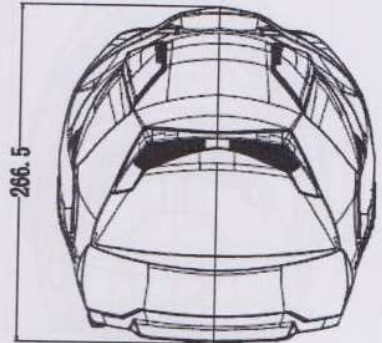
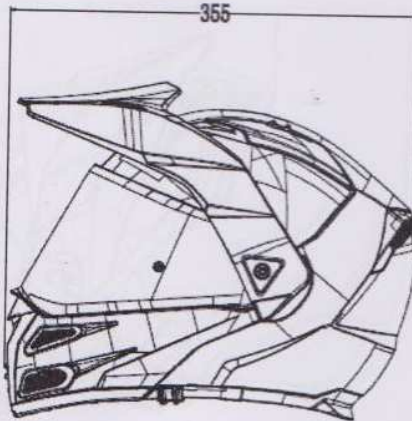
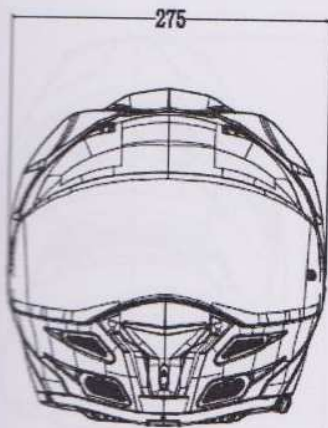

FF324-2-L-M

XS

eter

Feng

017

INFORMATION DOCUMENT

LS2

Type : FF324-2
 Manufacture : Jiangmen Pengcheng Helmets Co., Ltd.

R22-FF324-2-00

Date: 10.03.2017

Page 12 of 29

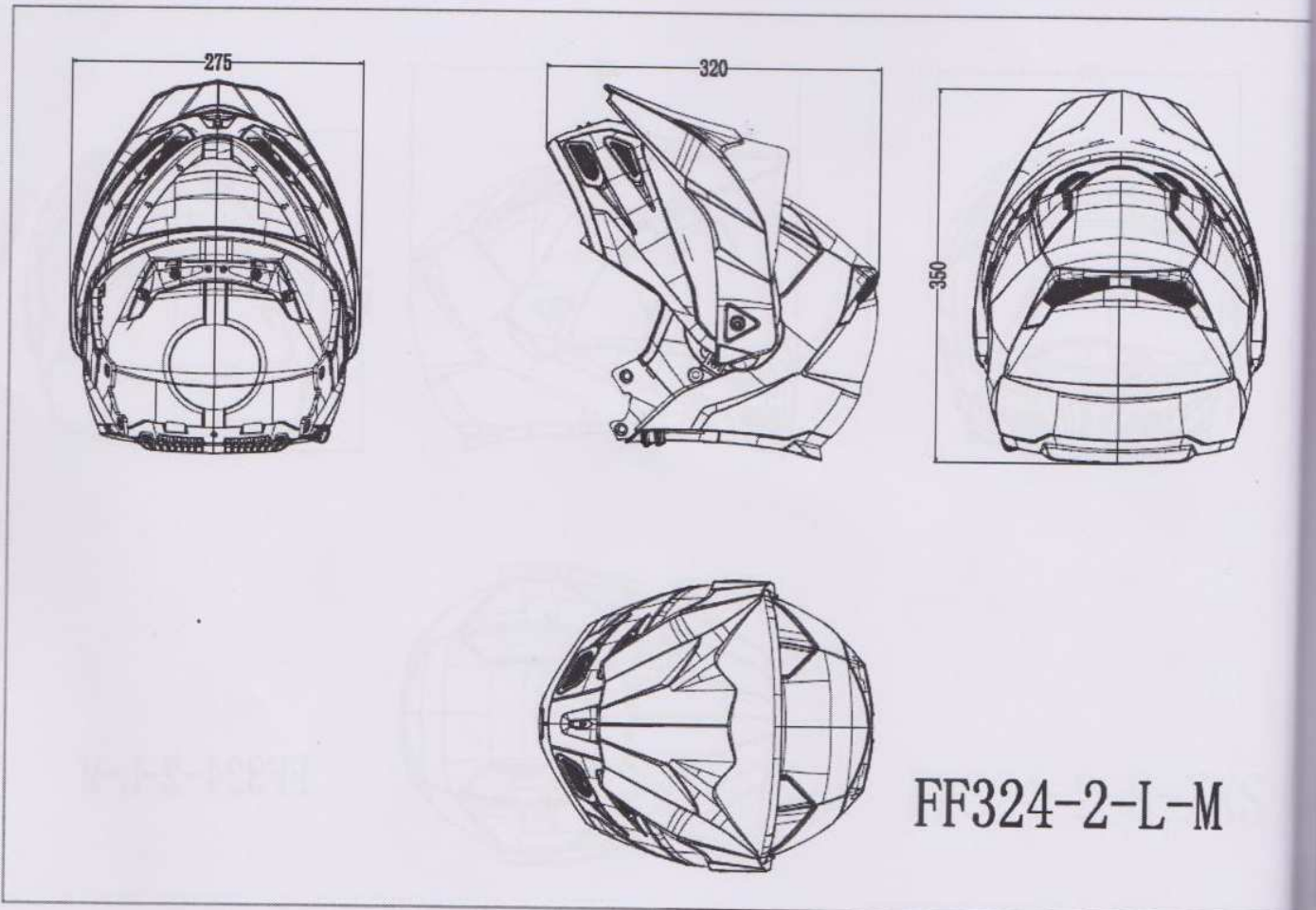

Unit: mm

Number	Name	Parameter	Number	Name	Parameter
1	Shell	ABS			
Description	FF324-2 Medium Shell		Code No.:	FF324-2.3.2	
Manufacturer:	Jiangmen Pengcheng Helmets Co., Ltd.				
Address:	Industrial Park East, Gonghe Town, Heshan City Guangdong Province, China				
Drawn by:	Xinsheng Liu	Checked by:	Xinsheng Liu	Approved by:	YouJunFeng
Date:	16.01.2017	Date:	26.02.2017	Date:	26.02.2017

INFORMATION DOCUMENT

R22-FF324-2-00

LS2

Type : FF324-2

Date: 10.03.2017

Manufacture : Jiangmen Pengcheng Helmets Co., Ltd.

Page 13 of 29

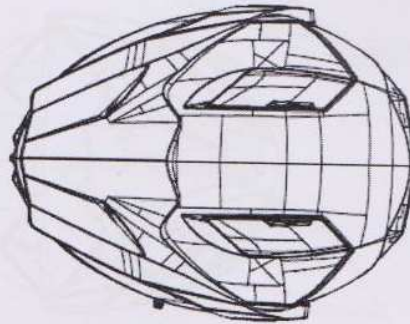
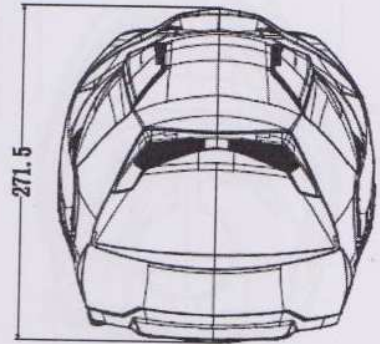
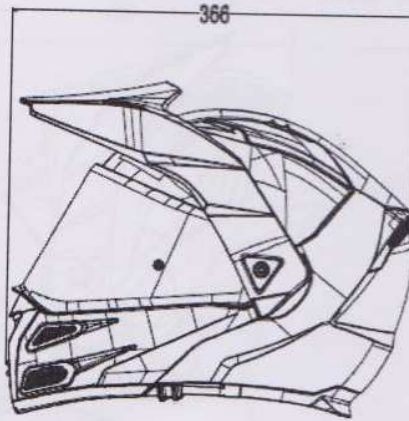

FF324-2XXXL-XL



Type : FF324-2
 Manufacture : Jiangmen Pengcheng Helmets Co., Ltd.

Date: 10.03.2017
 Page 14 of 29

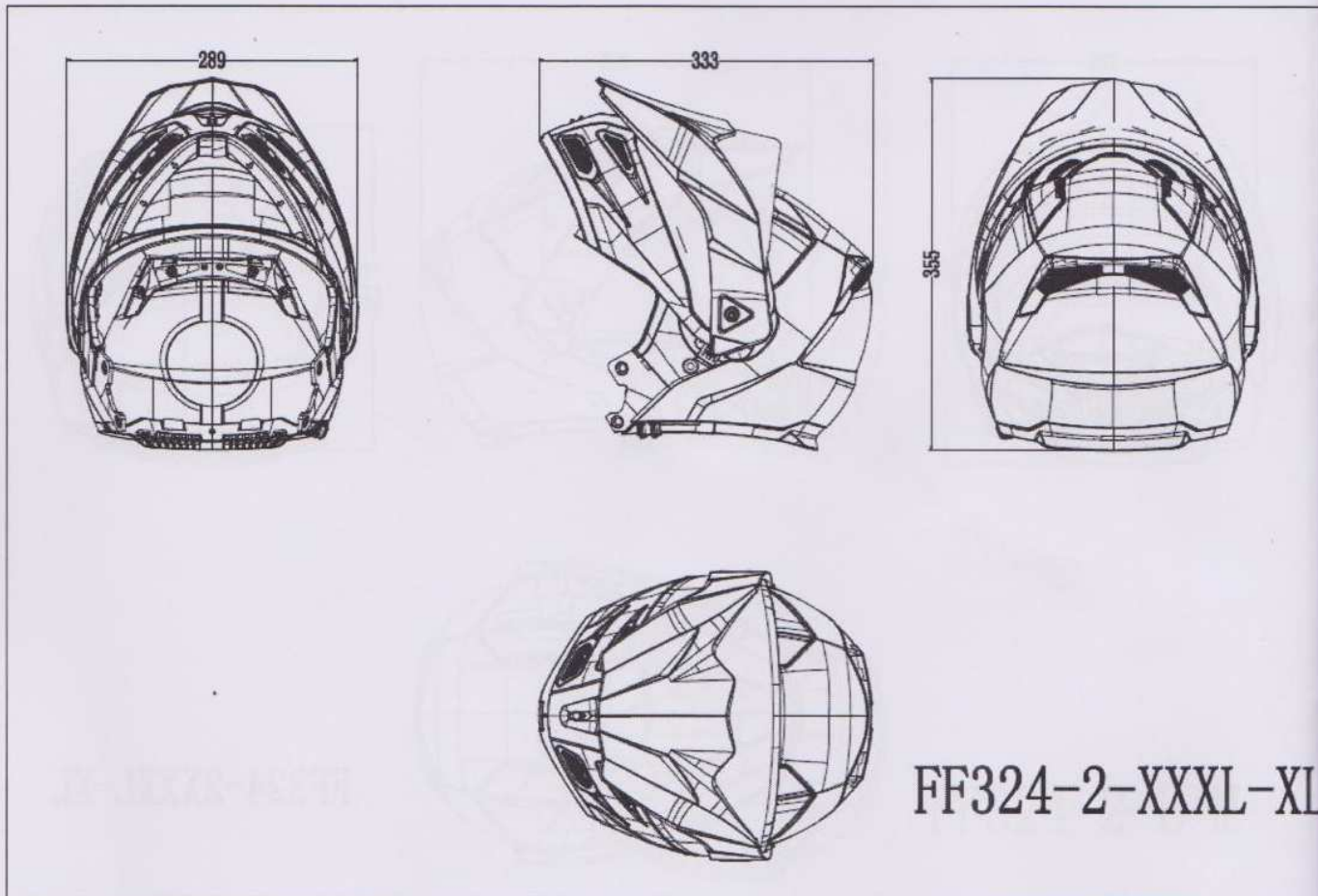

Unit: mm

Number	Name	Parameter	Number	Name	Parameter
1	Shell	ABS			
Description	FF324-2 Extra Large Shell		Code No.:	FF324-2.3.3	
Manufacturer:	Jiangmen Pengcheng Helmets Co., Ltd.				
Address:	Industrial Park East, Gonghe Town, Heshan City Guangdong Province, China				
Drawn by:	Xinsheng Liu	Checked by:	Xinsheng Liu	Approved by:	YouJunFeng
Date:	16.01.2017	Date:	26.02.2017	Date:	26.02.2017

2-00
2017
29

LS2

Type : FF324-2
Manufacture : Jiangmen Pengcheng Helmets Co., Ltd.

Date: 10.03.2017

Page 15 of 29

Annex 4: Drawing of the Peak

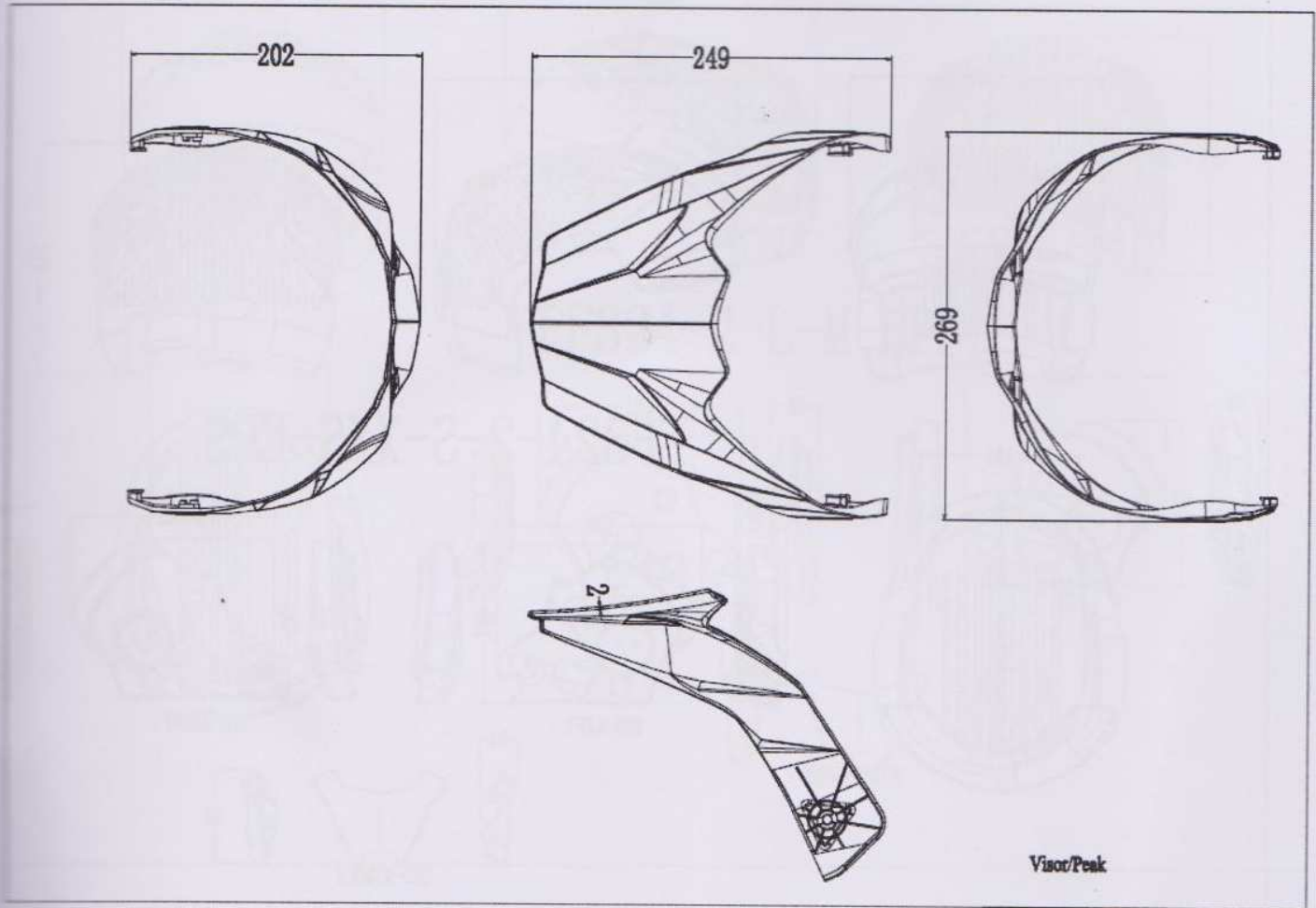

Unit: mm

Number	Name	Parameter	Number	Name	Parameter
1	Peak	Nylon			
Description	FF324-2 Peak		Code No.:	FF324-2.4.1	
Manufacturer:	Jiangmen Pengcheng Helmets Co., Ltd.				
Address:	Industrial Park East, Gonghe Town, Heshan City Guangdong Province, China				
Drawn by:	Xinsheng Liu	Checked by:	Xinsheng Liu	Approved by:	YouJunFeng
Date:	16.01.2017	Date:	26.02.2017	Date:	26.02.2017



Type : FF324-2
 Manufacture : Jiangmen Pengcheng Helmets Co., Ltd.

Date: 10.03.2017

Page 16 of 29

Annex 5: Drawing of the protective padding

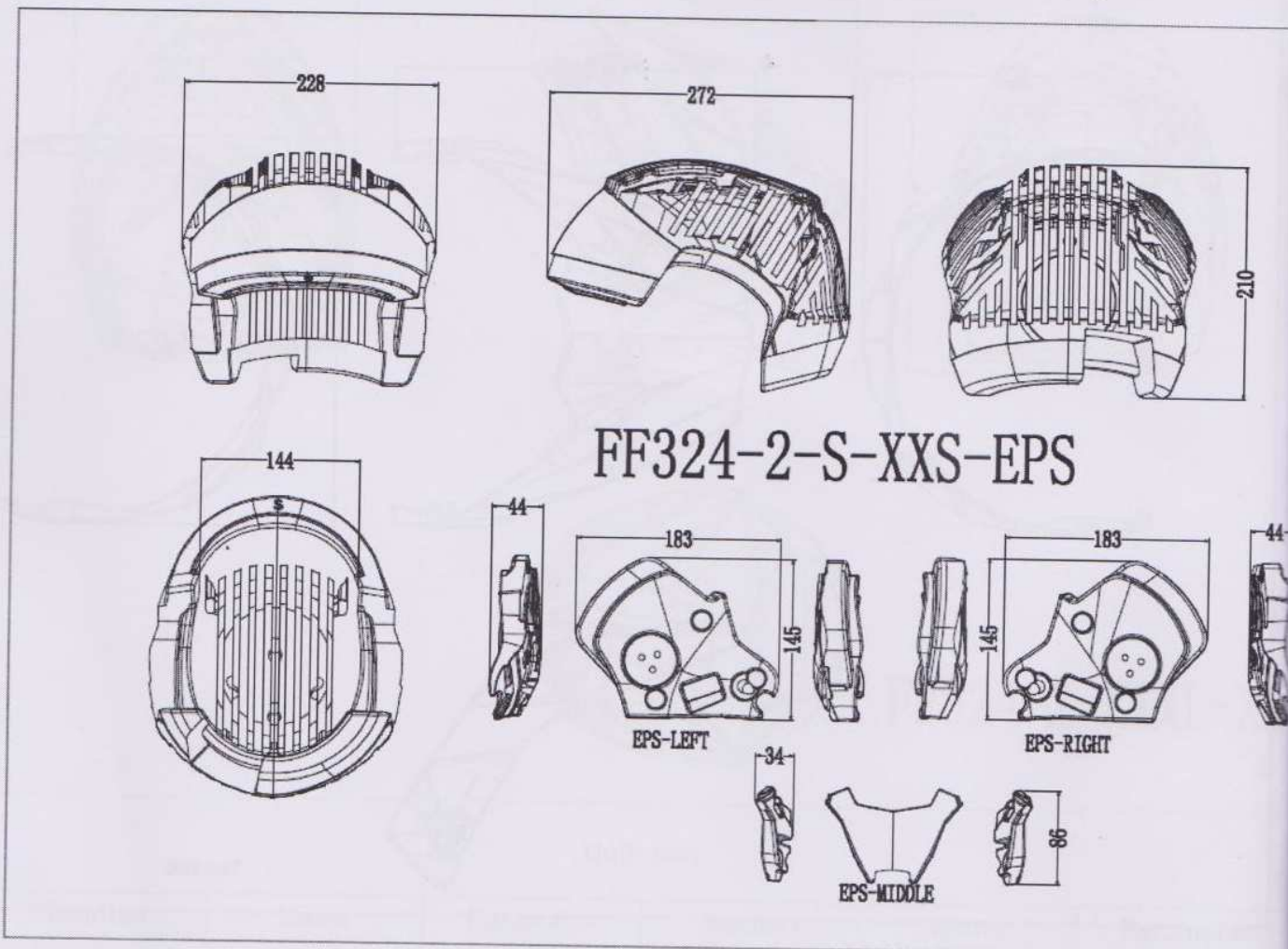

Unit: mm

Number	Name	Parameter	Number	Name	Parameter
1	Protective padding	EPS			
Description	FF324-2 S-XXS Protective padding		Code No.:	FF324-2.5.1	
Manufacturer:	Jiangmen Pengcheng Helmets Co., Ltd.				
Address:	Industrial Park East, Gonghe Town, Heshan City Guangdong Province, China				
Drawn by:	Xinsheng Liu	Checked by:	Xinsheng Liu	Approved by:	YouJunFeng
Date:	16.01.2017	Date:	26.02.2017	Date:	26.02.2017

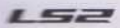

Type : FF324-2
 Manufacture : Jiangmen Pengcheng Helmets Co., Ltd.

Date: 10.03.2017

Page 17 of 29

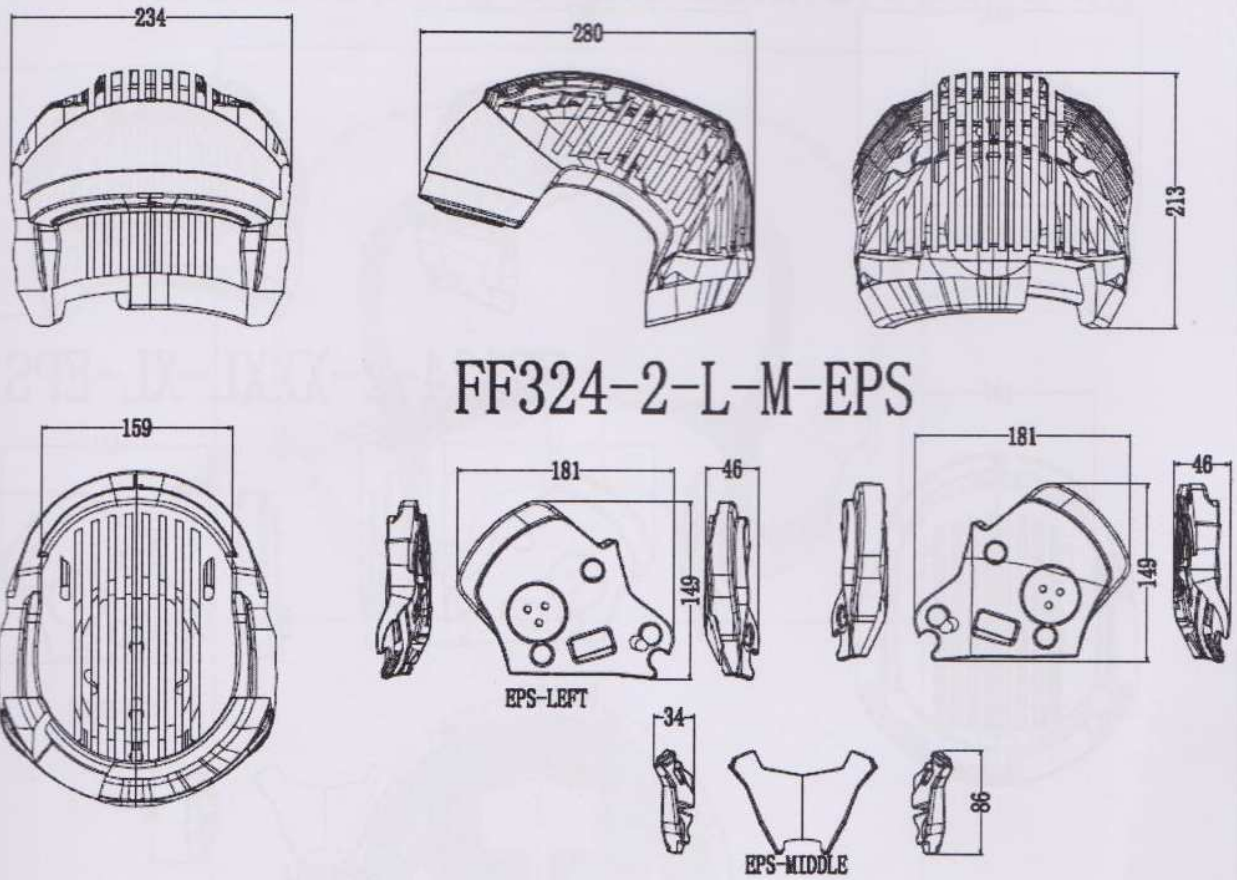

Unit: mm

Number	Name	Parameter	Number	Name	Parameter
1	Protective padding	EPS			
Description	FF324-2 L-M Protective padding		Code No.:	FF324.5.2	
Manufacturer:	Jiangmen Pengcheng Helmets Co., Ltd.				
Address:	Industrial Park East, Gonghe Town, Heshan City Guangdong Province, China				
Drawn by:	Xinsheng Liu	Checked by:	Xinsheng Liu	Approved by:	YouJunFeng
Date:	16.01.2017	Date:	26.02.2017	Date:	26.02.2017

INFORMATION DOCUMENT

LS2

Type : FF324-2
 Manufacture : Jiangmen Pengcheng Helmets Co., Ltd.

R22-FF324-2-00

Date: 10.03.2017

Page 18 of 29

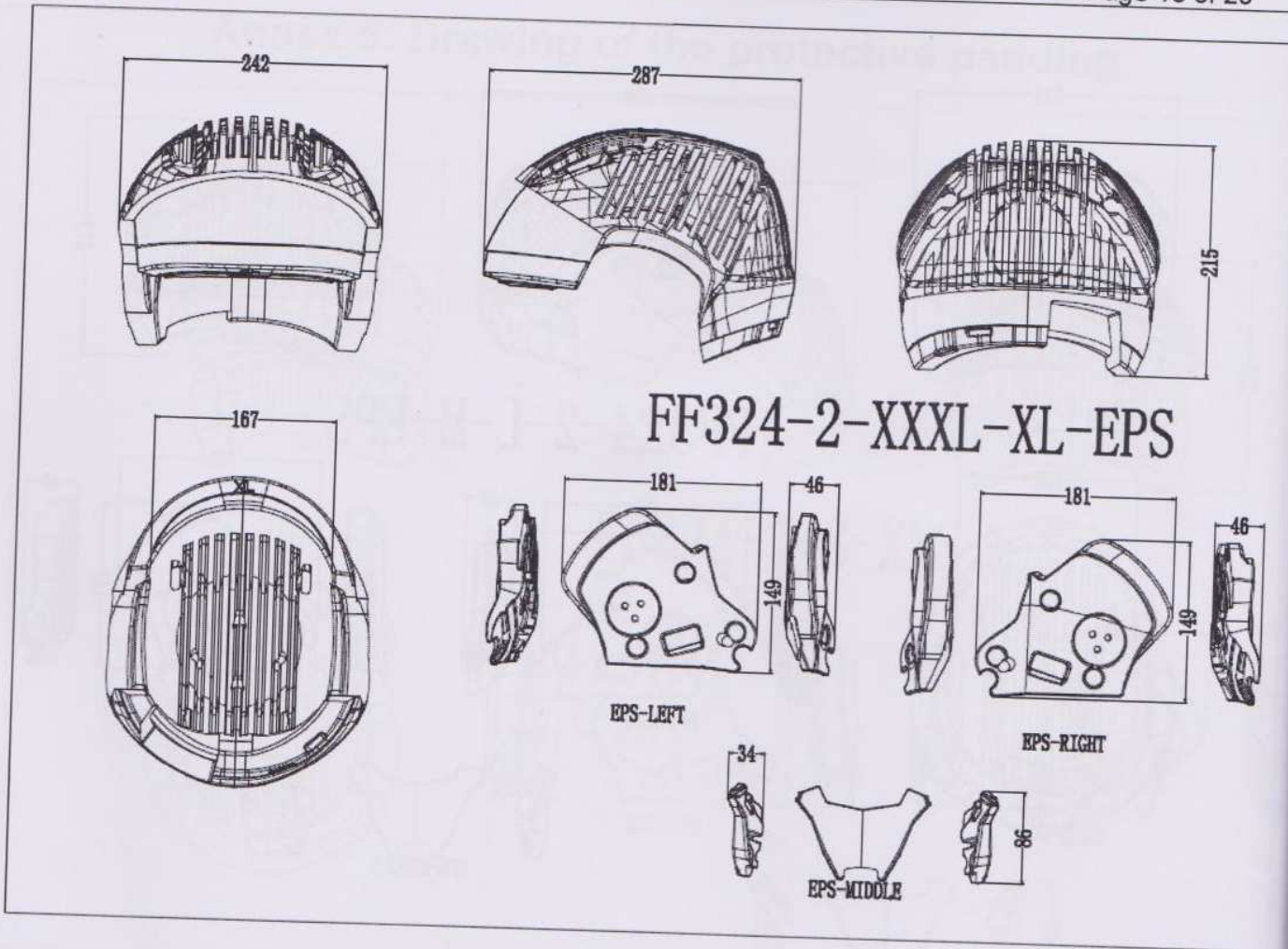

Unit: mm

Number	Name	Parameter	Number	Name	Parameter
1	Protective padding	EPS			
Description	FF324-2 XXXL-XL Protective padding		Code No.:	FF324-2.5.3	
Manufacturer:	Jiangmen Pengcheng Helmets Co., Ltd.				
Address:	Industrial Park East, Gonghe Town, Heshan City Guangdong Province, China				
Drawn by:	Xinsheng Liu	Checked by:	Xinsheng Liu	Approved by:	YouJunFeng
Date:	16.01.2017	Date:	26.02.2017	Date:	26.02.2017

Annex 6: Drawing of the comfort padding

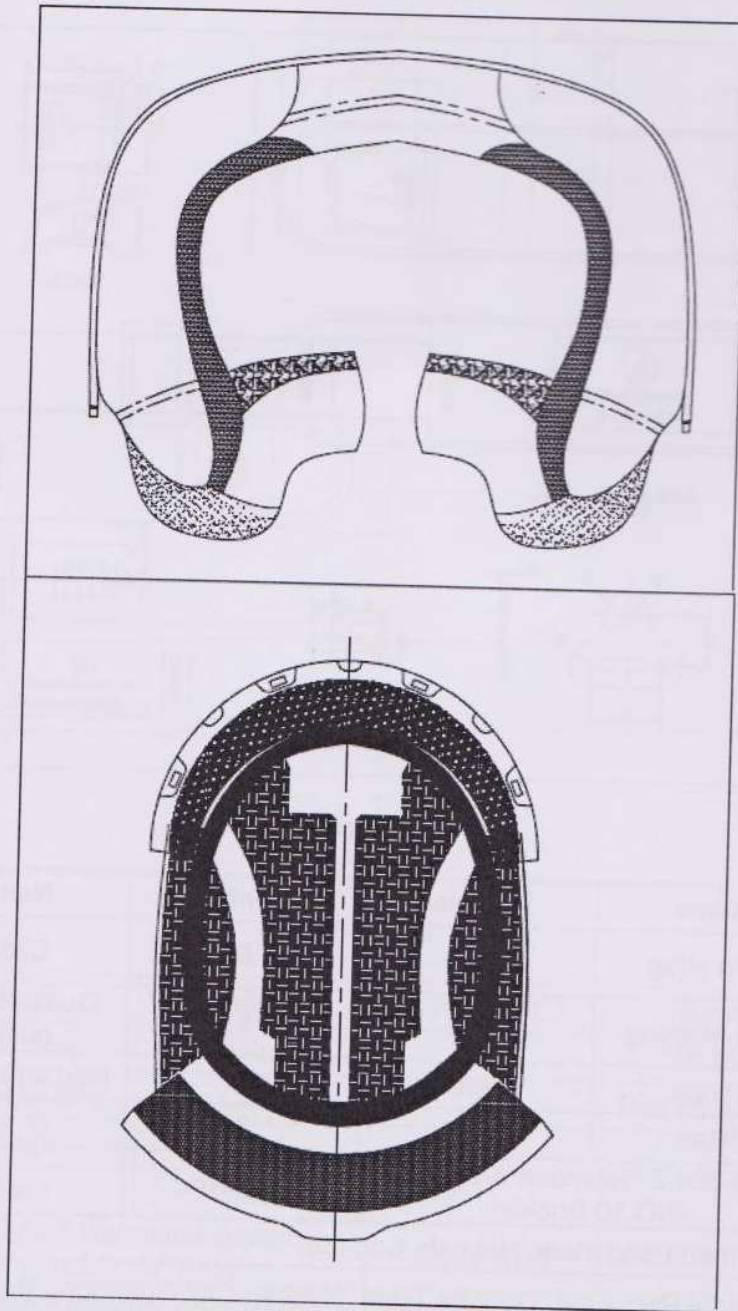

Number	Name	Material	Number	Name	Material
1	Comfort padding	Nylon	3	Ear chin strap padding	Nylon + PP
Description	FF324-2 Comfort padding		Code No.:	FF324-2.6.1	
Manufacturer:	Jiangmen Pengcheng Helmets Co., Ltd.				
Address:	Industrial Park East, Gonghe Town, Heshan City Guangdong Province, China				
Drawn by:	Xinsheng Liu	Checked by:	Xinsheng Liu	Approved by:	YouJunFeng
Date:	16.01.2017	Date:	26.02.2017	Date:	26.02.2017

INFORMATION DOCUMENT

R22-FF324-2-00

LS2

Type : FF324-2
 Manufacture : Jiangmen Pengcheng Helmets Co., Ltd.

Date: 10.03.2017

Page 21 of 29

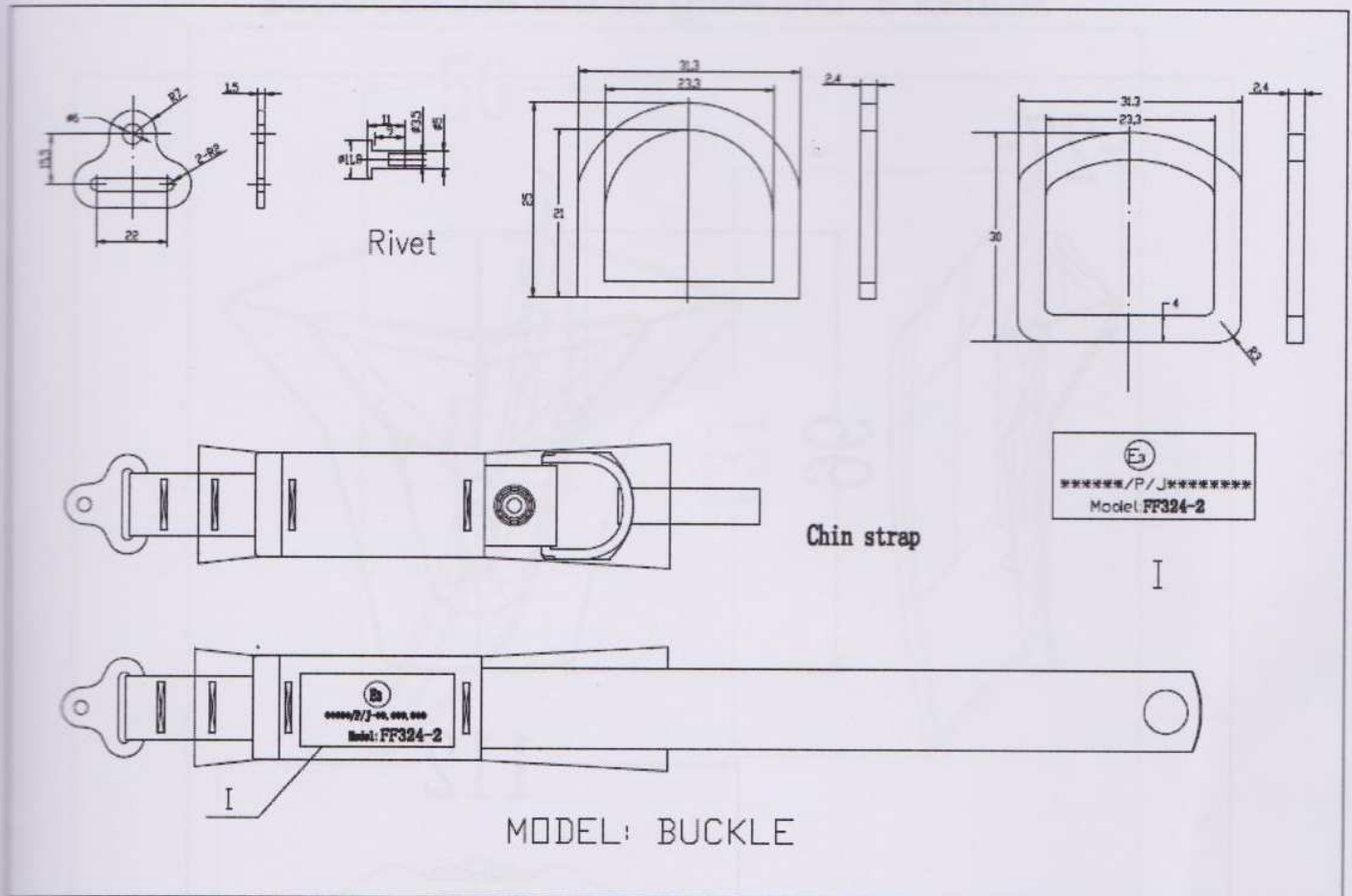

Unit: mm

Number	Name	Material	Number	Name	Material
1	Chin strap	Nylon	5	"D" Ring	Steel
2	ECE Marking	Cloth	6	Red small strap	Nylon
3	Hinge	Steel			
4	Rivet	Steel			
Description	FF324-2 Retention system (Double "D" Ring)		Code No.:	FF324-2.7.2	
Manufacturer:	Jiangmen Pengcheng Helmets Co., Ltd.				
Address:	Industrial Park East, Gonghe Town, Heshan City Guangdong Province, China				
Drawn by:	Xinsheng Liu	Checked by:	Xinsheng Liu	Approved by:	YouJunFeng
Date:	16.01.2017	Date:	26.02.2017	Date:	26.02.2017

Annex 8: Drawing of the accessories

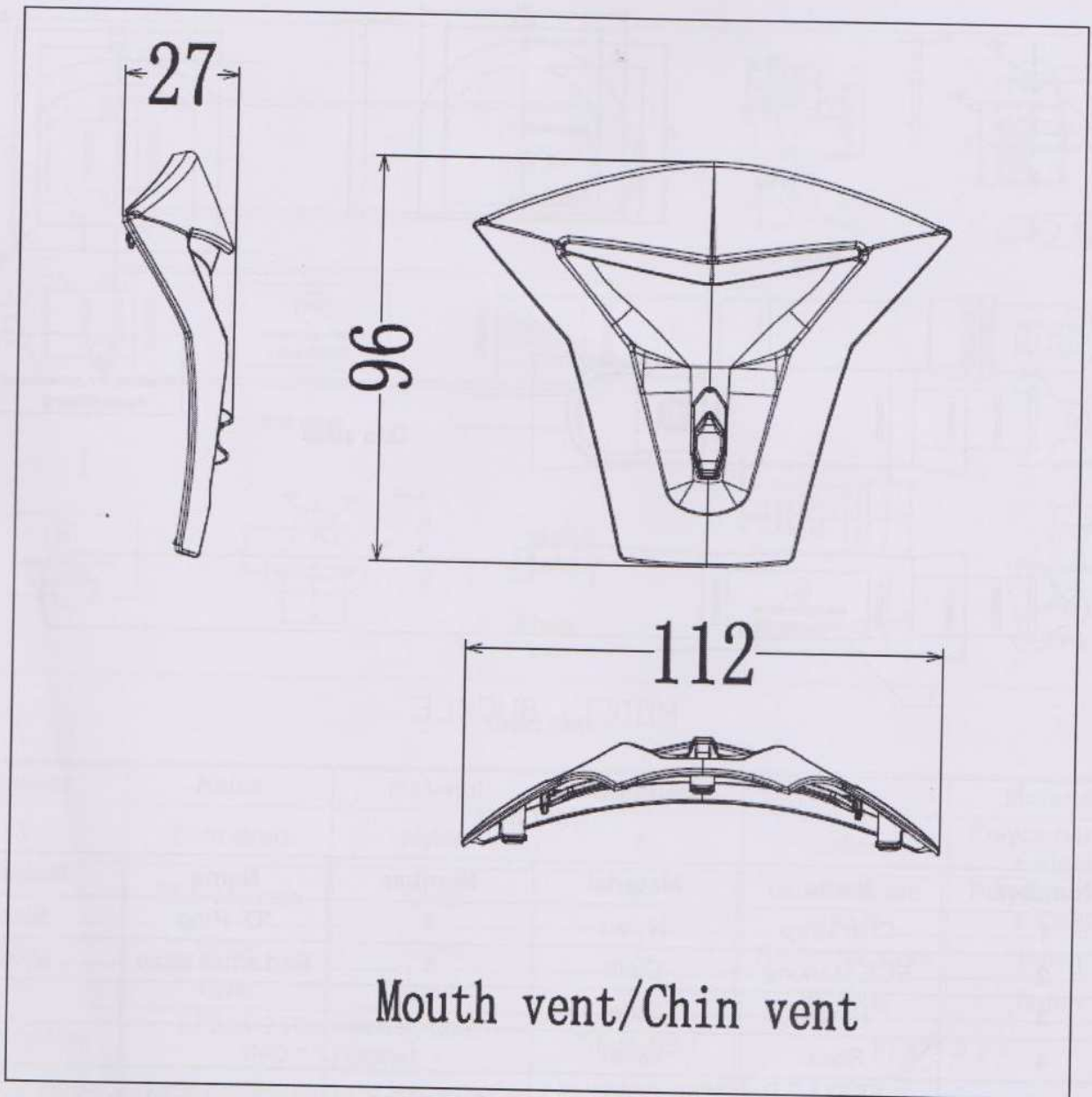

Unit: mm

Number	Name	Parameter	Number	Name	Parameter
1	Chin Vent	ABS			
Description	FF324-2 Chin Ventl		Code No.:	FF324-2.8.1	
Manufacturer:	Jiangmen Pengcheng Helmets Co., Ltd.				
Address:	Industrial Park East, Gonghe Town, Heshan City Guangdong Province, China				
Drawn by:	Xinsheng Liu	Checked by:	Xinsheng Liu	Approved by:	YouJunFeng
Date:	16.01.2017	Date:	26.02.2017	Date:	26.02.2017



Type : FF324-2
 Manufacture : Jiangmen Pengcheng Helmets Co., Ltd.

Date: 10.03.2017

Page 23 of 29

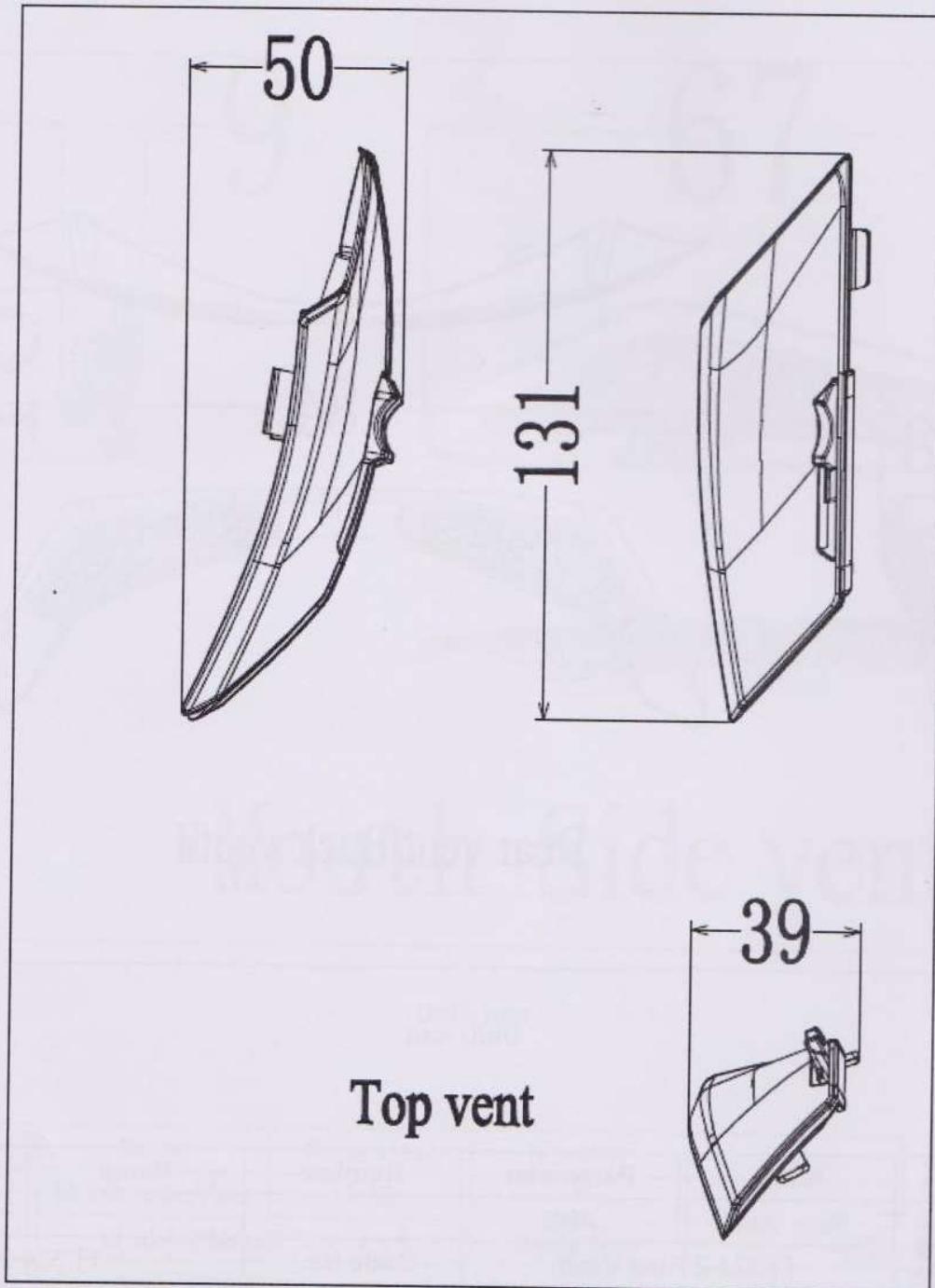

Unit: mm

Number	Name	Parameter	Number	Name	Parameter
1	Top Vent	ABS			
Description	FF324-2 Top Vent		Code No.:	FF324-2.8.2	
Manufacturer:	Jiangmen Pengcheng Helmets Co., Ltd.				
Address:	Industrial Park East, Gonghe Town, Heshan City Guangdong Province, China				
Drawn by:	Xinsheng Liu	Checked by:	Xinsheng Liu	Approved by:	YouJunFeng
Date:	16.01.2017	Date:	26.02.2017	Date:	26.02.2017

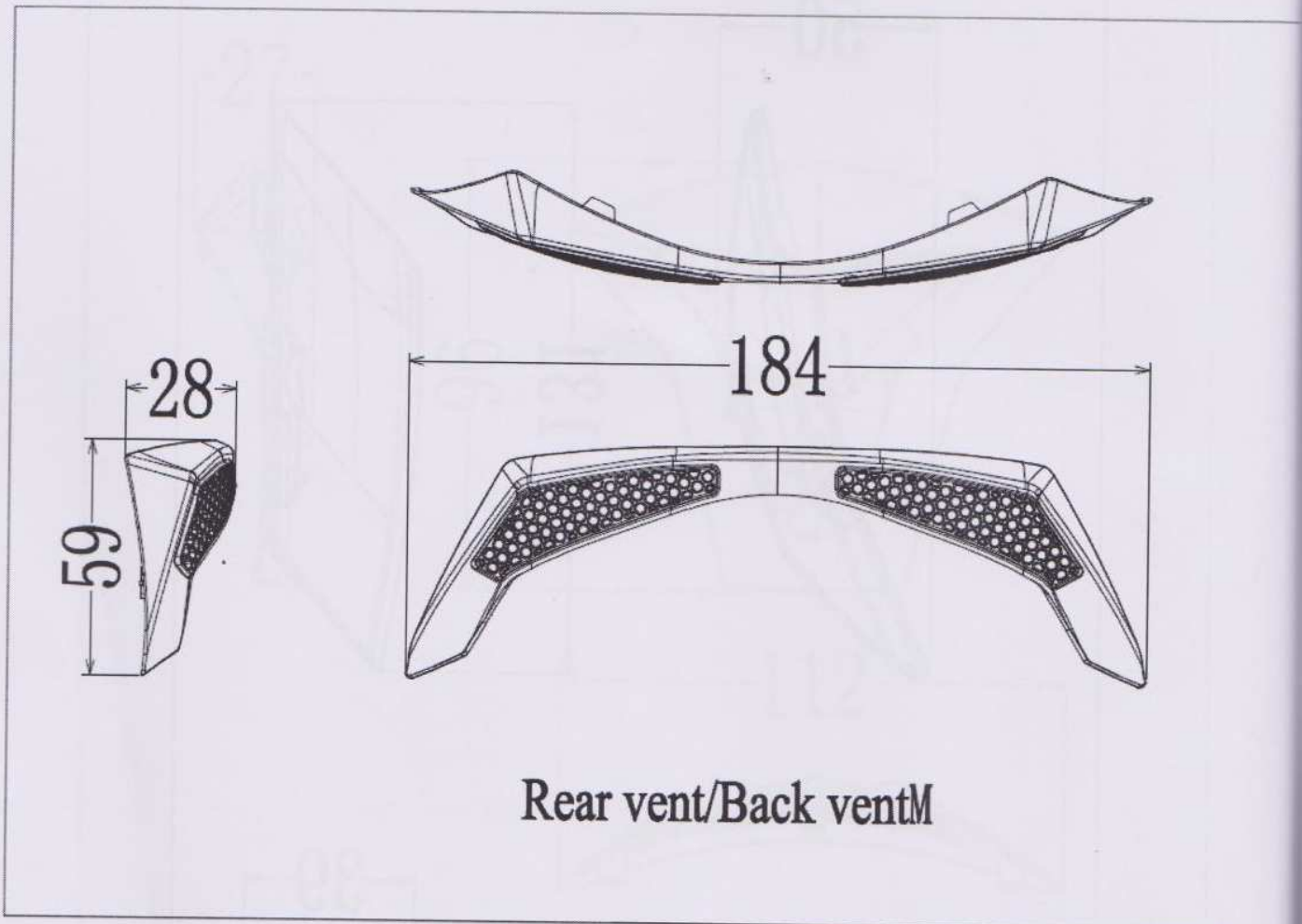

Unit: mm

Number	Name	Parameter	Number	Name	Parameter
1	Rear Ventl	ABS			
Description	FF324-2 Rear Ventl		Code No.:	FF324-2.8.3	
Manufacturer:	Jiangmen Pengcheng Helmets Co., Ltd.				
Address:	Industrial Park East, Gonghe Town, Heshan City Guagdong Province, China				
Drawn by:	Xinsheng Liu	Checked by:	Xinsheng Liu	Approved by:	YouJunFeng
Date:	16.01.2017	Date:	26.02.2017	Date:	26.02.2017



Type : FF324-2
Manufacture : Jiangmen Pengcheng Helmets Co., Ltd.

Date: 10.03.2017

Page 25 of 29

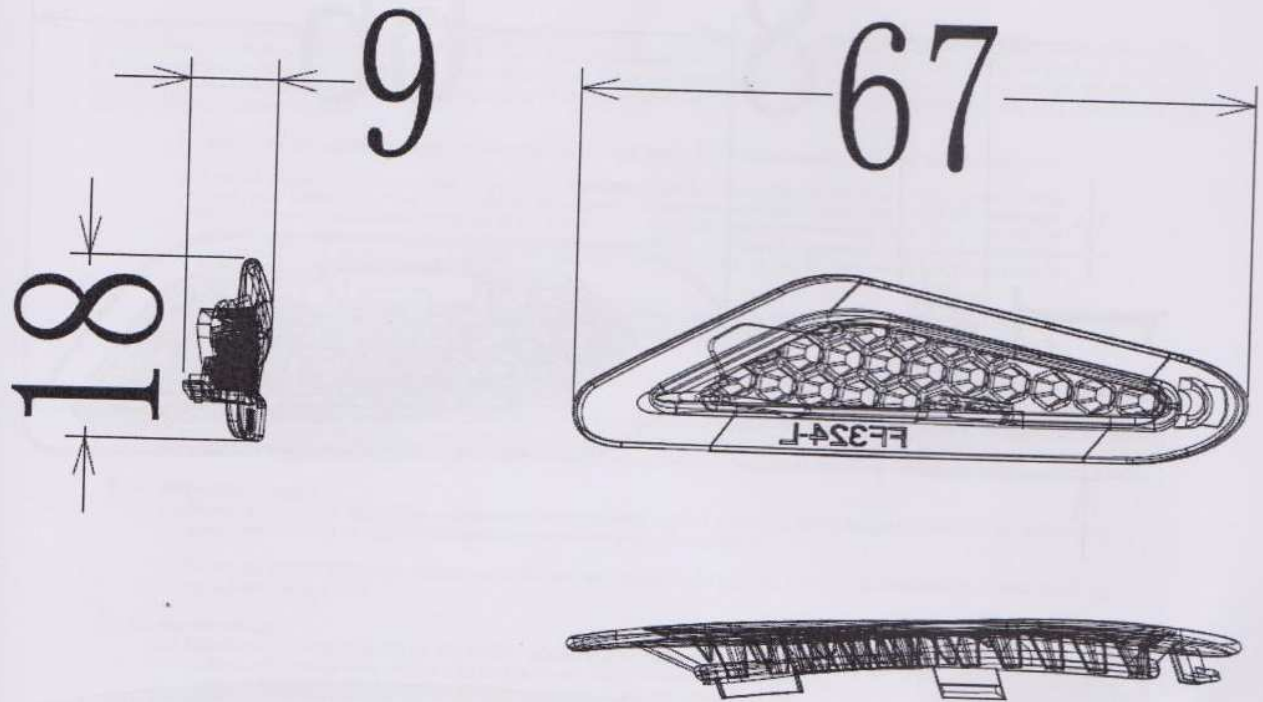

Mouth Side vent

Unit: mm

Number	Name	Parameter	Number	Name	Parameter
1	Mouth Side Vent	ABS			
Description	FF324-2 Mouth Side Vent		Code No.:	FF324-2.8.4	
Manufacturer:	Jiangmen Pengcheng Helmets Co., Ltd.				
Address:	Industrial Park East, Gonghe Town, Heshan City Guangdong Province, China				
Drawn by:	Xinsheng Liu	Checked by:	Xinsheng Liu	Approved by:	YouJunFeng
Date:	16.01.2017	Date:	26.02.2017	Date:	26.02.2017

Type : FF324-2
 Manufacture : Jiangmen Pengcheng Helmets Co., Ltd.

Date: 10.03.2017

Page 26 of 29

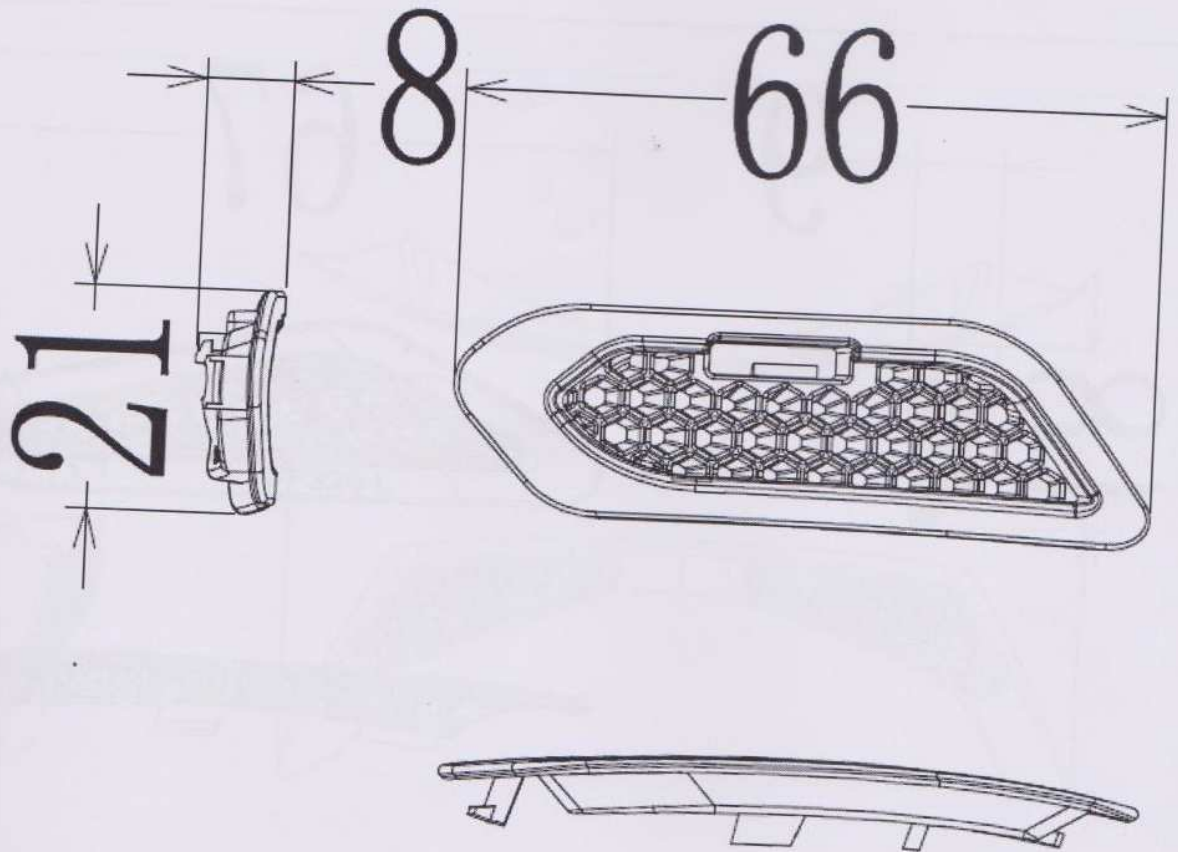

Mouth Side vent

Unit: mm

Number	Name	Parameter	Number	Name	Parameter
1	Mouth Side Vent	ABS			
Description	FF324-2 Mouth Side Vent		Code No.:	FF324-2.8.5	
Manufacturer:	Jiangmen Pengcheng Helmets Co., Ltd.				
Address:	Industrial Park East, Gonghe Town, Heshan City Guangdong Province, China				
Drawn by:	Xinsheng Liu	Checked by:	Xinsheng Liu	Approved by:	YouJunFeng
Date:	16.01.2017	Date:	26.02.2017	Date:	26.02.2017

Type : FF324-2
 Manufacture : Jiangmen Pengcheng Helmets Co., Ltd.

Date: 10.03.2017

Page 27 of 29

Annex 9:Information for wearer

Congratulations on purchasing your new **LS2** helmet. Please read these instructions carefully before use. They contain valuable informations to help you obtain the most protection from your helmet and to ensure a longer life for your helmet. All our products come from the most advanced research in terms of active security and design. The very high level for aerodynamism and comfort will get you the best performances all along the road. Whatever can be your choice leisure, tourism, racing, one of the helmets from the LS2 range is the best solution for your active protection.

1. Read these instructions thoroughly before using your helmet for the first time and store them safely for future reference.
2. A helmet like all products may wear out over time depending upon its use and the amount of care that is given. Please check your helmet every time before use for damage and do not use a damaged helmet. The most known standards of homologation recommend a helmet life of five years. LS2 agrees with their recommendation even though your helmet does not show any signs of malfunction, visible damage or defect. We strongly recommend you replace your helmet five years after the original date of purchase. See also "ONE IMPACT RULE" of item 3 in this manual, which says clearly "helmet is designed to help absorb one impact".
3. If you have any questions or comments concerning this helmet, please contact your nearest LS2 dealer or agent. Note that these specifications are subject to change without notice, as we continually strive to improve our products.

HOW TO CHOOSE A HELMET AND WEAR IT CORRECTLY

No helmet can protect the wearer against all foreseeable high speed and low speed impact, however, for maximum head protection the helmet must be of proper fit and the retention system must be securely fastened under the chin. Failure to have proper fit and to securely fasten the helmet is dangerous as the helmet could come off in an accident resulting in severe head injury or death.

1 To determinate proper fit.

- 1.1. Measure your head size. Wrap a tape measure horizontally around your head at the height of about 2.5 cm above your eyebrows. This will establish the longest measurement around your head.
- 1.2. Select the helmet that is the closest match to your head size. If your head size should fit between two helmet sizes, try on the smaller one first.

2 Try the helmet on

- 2.1. Expand the helmet opening by the straps, and slide your head into the helmet. Pull the chin straps only, not the chin straps cover, pulling on the covers may rip them. If the helmet is not tight, it is too big for you. If you are unfamiliar with helmets you may be reluctant to pull down the helmet which should feel tight. Even if you feel it is difficult to put it on, please use the smallest helmet possible.

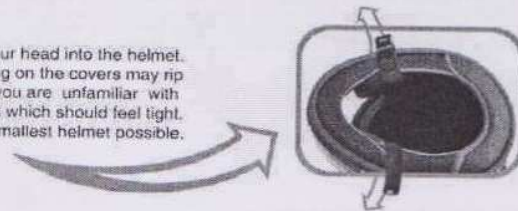

3 Check for a proper fit. With the helmet, go through the following checklist to determine whether the helmet is the correct size.

- 3.1. Make sure the inner lining fits snugly all around your head.
- 3.2. Make sure the top pad presses closely to the top of your head.
- 3.3. Check whether the cheek pads are in contact with your cheeks.
- 3.4. Make sure there is no space between inner lining and brow where you could insert your finger.
- 3.5. Now, take hold of the helmet with a hand on each side. Without moving your head, try to move the helmet up and down, and side to side. You should feel the skin of your head and face being pulled as you try to move the helmet. If you can move the helmet around easily, it is too big. Try a smaller size.



4 Check the retention system and go through the following steps.

- 4.1. Fasten the chinstrap as tight as possible without causing you pain (see diagram 2). There must be no slack in the strap and it must be tight up against your chin.
- 4.2. With the chinstrap secured, put your hands flat on the back of the helmet and try to push the helmet off by rotating forward.
- 4.3. Next, put your hands on the front of the helmet above your forehead (or on the chinguard) and try to push the helmet off by rotating it toward the rear.
- 4.4. If the helmet starts to come off in either direction, do not use the helmet, either the helmet is too large for you or the chin strap is not tightened enough.

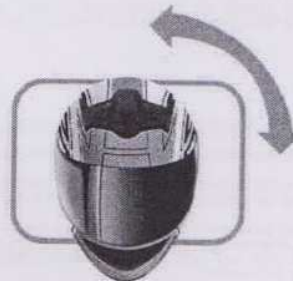

ENGLISH

Tightening the chinstrap correctly is extremely important. Try to pull down on the chinstrap with the tips of your fingers if the strap is not against your chin or loosens, you have not properly put the strap through the D rings. Start again (see diagram 2) if your chinstrap is loose, the shock of an impact may knock your helmet off, leaving your head completely unprotected. Do not use a helmet that can be rolled off the head with the chinstrap fastened, since it may come off in an accident, resulting in death or serious personal injuries.



Type : FF324-2
 Manufacture : Jiangmen Pengcheng Helmets Co., Ltd.

Date: 10.03.2017

Page 28 of 29

D RING: To securely fasten the D ring retention system, thread the end of the chinstrap through the D rings only as shown in diagram 2 and put it tight against your throat. Clip the chin strap end hook on the D ring as shown in diagram 2 to secure the loose end of the chin strap after it's securely fastening the chin strap. The only function of the chinstrap end hook fitted on the end of the chinstrap is to avoid fluttering of the end part of the chinstrap.

Quick-release retention system: To fasten the strap, push the metal tongue firmly into the buckle until it locks with a click. Pull the strap tight and pass the end of the strap through the strap ring or ladder to secure it. To release the strap, press the two catches inward (or slide the catches down).

SAFETY RECOMMENDATIONS

1

No helmet can protect wearer against all foreseeable high speed and low speed impacts.
 However, for maximum head protection, the helmet must be of proper fit and retention system must be securely fastened under the chin. The helmet should allow peripheral vision when secure on your head. If your helmet is too large, it may sleep or move on your head while riding which may make it possible for your helmet to come off in an accident or to obstruct your vision while riding. In the first case, your helmet will not protect your head in an accident, which can result in serious personal injury or death and in the second case, if you cannot see you may have an accident.

2

Use only a helmet that fits snugly all around your head, and fasten the chinstrap securely under your chin.
 Expand the helmet opening with your hands, and slide your head into the helmet. Please check whether the helmet fits properly according to the checklist (paragraph 3, page 3). Pull the chinstraps only, not the chinstraps covers. Pulling on the covers may rip them, if the helmet is not tight, it is too big for you. To securely fasten the D ring retention system, thread the end of the chinstrap through the D rings only as shown, and pull it tight up against your throat. In the case of quick-release retention system, refer to upper paragraph. If your chinstrap is loose, the shock of an impact may knock your helmet off leaving your head completely unprotected resulting in serious personal injury or death.

3

Helmets are designed to help absorb ONE impact. After your helmet has protected you from an impact, you must get a new one.
 Your helmet is designed to distribute the force incurred during an impact over a wide area. Even if your helmet looks undamaged externally its useful life is finished after one impact during riding, for example, a capsized or accident where you and your helmet hit the ground or some object. In an impact, the helmet's impact absorbing liner becomes compacted. Once this has happened, the helmet no longer has the ability to absorb further impacts. Your helmet may look the same, but it will not provide protection in an accident. If you have any doubts, for example, if you drop your helmet or if it is hit by something and you are not sure if this one impact rule applies, consult your LS2 dealer before you use the helmet again.



page 4

4

Clean your helmet carefully.
 Never use hot or salt water, benzene, gasoline, glass cleaner or other solvents. Your helmet could be seriously damaged by these substances, without showing any apparent visible damage. A helmet damaged or weakened by a cleaning agent may not provide head protection in an accident resulting in serious personal injury or death. The correct way to clean a helmet is to mix 5 or 6 drops of mild soap in a quart of warm water. Dampen a soft cloth with this solution and wipe the helmet clean. Rinse with a wet cloth.

5

Never modify your helmet.
 It is very dangerous to drill holes or cut the shell and/or the shock absorber liner. Modifications can seriously weaken the helmet. Modifying the retention system weakens it, and it may snap in an impact removing parts such as the mouth guard or rubber face trim can expose edges, which may injure you in an accident. Always use approved LS2 parts when replacing shields, screws, or any other parts. A weakened helmet will not provide protection.

6

Don't mistreat your helmet.
 Never ride with the helmet hanging from the helmet holder, and don't hang the helmet from angled supports like a mirror. Don't sit on your helmet or throw it around. You should not expose the liner of your helmet to strong sunlight and excessive heat such as near heaters or where temperatures exceed 50° C (122 F). Avoid the spray of insect repellent chemicals (such as "naphthalene") near the helmet. Mistreating your helmet will damage the shell and impact absorbing liner and reduce the helmet's ability to protect you in an accident.

7

Always check your helmet before riding off.

1. Check the shield and visor screws, and retighten them if necessary.
2. Check for cracks in the helmet. Strong acid (for example, battery acid) can damage the shield base. If you find cracks or damage, stop using the helmet immediately.
3. Plastic components may start to wear out about 5 years after manufacture. If you find deterioration in any part of a component, either replace that component or get a new helmet. If these parts come loose and / or fall off while you are riding, your vision may be blocked which could cause an accident resulting in serious personal injury or death.
4. Check the security of the retention system
5. Make sure that the center pad (or comfort liner) and the cheek pads are attached before you use the helmet.

page 5



ENGLISH



Type : FF324-2
Manufacture : Jiangmen Pengcheng Helmets Co., Ltd.

Date: 10.03.2017

Page 29 of 29

8

Maintain your helmet shield in good condition.

If your shield becomes too scratched or undeanable, replace it with a new one. Impaired visibility causes accidents. Clean your shield with mild soapy water, rinse well with clean water and dry with a soft cloth. Never use benzene, gasoline, glass cleaner or any other solvents. Do not attach stickers or adhesive tape to the shield, as this will weaken the hard coating. This can damage the shield. Do not drive with a dim or blurred face shield. Impaired vision can cause an accident resulting in serious personal injury or death.

9

Do not repaint the helmet.

We do not recommend you repaint the helmet, because paint and thinner can damage the materials used in the helmet construction. A helmet damaged weakened by a paint agent may not provide head protection in an accident resulting in serious personal injury or death. If you must paint your helmet, please consult your LS2 dealer.

10

Remember: helmets block important sounds and reduce awareness of environmental changes.

When you wear a helmet, especially a full-face type, you are somewhat isolated from the environment around you. Weather changes can catch you unprepared; sudden showers or temperature variations as you enter or leave tunnels or climb mountain roads can cause unexpected misting of your shield and loss of visibility. Do not drive with a fogged face shield. Wearing a helmet also reduces your ability to hear traffic sounds, especially of high speed. With a full face helmet, opening and closing the shield makes a major difference in how much you can hear. For safe riding be aware of how your helmet type, your speed, affects your perception of road conditions and whether your shield is open.

